



SWIFT

SWIFT GROUP TECHNICAL HANDBOOK

TOURING CARAVANS

Issued September 2024

Part No. 1452040

Contents

Basecamp Specification	4
Sprite Specification	6
Sprite Grande Specification	8
Challenger Specification	14
Challenger Grande Specification	16
Challenger Exclusive Specification	18
Challenger Grande Exclusive Specification	20
Elegance Grande Specification	22
Wiring Diagrams - Road Lighting	24
Wiring Diagrams - Consumer Circuits	27
Wiring Diagrams - Consumer Circuits - Roof	30
Wiring Diagrams - Power Circuits	33
Wiring Diagrams - 230V Circuits	38
Wiring Diagrams - 13 Pin Socket	39
Wiring Diagrams - Cable Colour Chart	40
Bulb Replacement	41
Dealer Special specification based on Elegance Grande	42
Bed make up	44

Basecamp Specification

Basecamp	Basecamp 2	Basecamp 3
Berths	2	3
Axles	1	1
Internal Length (bed box height)	3.42m / 11'3"	3.91 / 12'10"
Overall Width**	2.28m / 7'6"	2.28m / 7'6"
Overall Height (inc. TV Aerial)**	2.60m / 8'6"	2.61m / 8'7"
Maximum Internal Headroom	1.95m / 6'5"	1.95m / 6'5"
Overall Length**	5.10m / 16'9"	5.59m / 18'4"
Mass in Running Order (inc. tolerance)	932kg / 18.3cwt	1000kg / 19.7cwt
Maximum Technical Permissible Laden Mass (Lower limit)	1043kg / 20.5cwt	1126kg / 22.2cwt
Maximum Technical Permissible Laden Mass (Upper limit)	1300kg / 25.6cwt	1400kg / 27.6cwt
Total user Payload	111kg / 2.2cwt	126kg / 2.6cwt
Personal Effects	111kg / 2.2cwt	126kg / 2.6cwt
Options	0kg / 0.0cwt	0kg / 0cwt
Tyre Size	225/50 R17 98 Y	225/50 R17 98 Y
Tyre pressure at Lower limit MTPLM	2.7 bar / 39 psi	2.8 bar / 41 psi
Tyre pressure at Upper limit MTPLM	3.3 bar / 48 psi	3.4 bar / 49 psi
Static Load on Coupling Head	100kg	100kg
Thermal Insulation Grade	THREE	THREE
Bed Sizes		
Front Double	198cm x 183cm / 6'6" x 6'0"	198cm x 130cm / 6'6" x 4'3"
or Front Nearside Single	183cm x 69cm / 6'0" x 2'3"	
and Front Offside Single	183cm x 69cm / 6'0" x 2'3"	
Side Bunk Nearside (upper)		
Side Bunk Nearside (lower)		178cm x 62cm / 5'10" x 2'0"

Masses: The masses are calculated in accordance to EU regulation 1230 / 2012 and NCC code of practice 304.

The Mass in Running Order (MRO) comprises:

1. The mass of the empty caravan as supplied by Swift including loose items such as the hook-up cable, kit bag, entrance step, manuals etc.
2. 10kg allowance for LPG

The MRO is calculated with the fresh water tank, toilet flush tank and water heater empty. If you travel with water in the fresh water tank, toilet flush tank and the water heater the payload will reduce accordingly.

The personal effects is based on the number of berths and the length of the caravan and includes an allowance of 20kg for a leisure battery.

The Maximum Technical Laden Mass (MTPLM) is the maximum mass allowed when the caravan is fully laden.

WARNING: Under no circumstances should the MTPLM be exceeded

Basecamp 4
4
1
3.91m / 12'10"
2.28m / 7'6"
2.61m / 8'7"
1.95m / 6'5"
5.59m / 18'4"
1010kg / 19.9cwt
1146kg / 22.6cwt
1400kg / 27.6cwt
136kg / 2.7cwt
136kg / 2.7cwt
0kg / 0.0cwt
225/50 R17 98Y
2.8 bar / 41 psi
3.4 bar / 49 psi
100kg
THREE
198cm x 130cm / 6'6" x 4'3"
178cm x 54cm / 5'10" x 1'9"
178cm x 54cm / 5'10" x 1'9"

Bed Sizes: Please note that the front double bed sizes quoted are for seating configurations without chest of drawers. The front double bed width for a layout with a chest of drawers fitted will be reduced by 0.4m (1'4") from that stated.

Awning sizes: Due to the varying awning designs and sizes the awning sizes given are approximate only. Specific awning sizes must be confirmed by your dealer or the awning manufacturer prior to purchase.

Est = Estimated weight or bed size

**The dimensions given are approximate due to slight variations in suspension ride heights, loading conditions and tyre pressures.

Customers should verify the actual dimensions of their touring caravan before committing to anything that could be impacted by these dimensions

Please note: Any dealer fit options will reduce the overall payload available to the user of the caravan.

If you require additional payload it is possible to upgrade the MTPLM to the upper limit. Please contact your caravan dealer for more information.

Sprite Specification

Sprite	Compact	Alpine 2	Alpine 4	Major 4 SB
Berths	2	2	4	4
Axles	1	1	1	1
Internal Length (bed box height)	3.66m / 12'0"	4.34m / 14'3"	4.83m / 15'10"	5.83m / 19'2"
Overall Width**	2.03m / 6'8"	2.25m / 7'5"	2.25m / 7'5"	2.25m / 7'5"
Overall Height (inc. TV Aerial)**	2.59m / 8'6"	2.59m / 8'6"	2.59m / 8'6"	2.59m / 8'6"
Maximum Internal Headroom	1.95m / 6'5"	1.95m / 6'5"	1.95m / 6'5"	1.95m / 6'5"
Overall Length**	5.37m / 17'7"	6.05m / 19'10"	6.53m / 21'5"	7.54m / 24'9"
Awning A / A dimension	7.95m / 26'1"	8.59m / 28'2"	10.02m / 32'10"	10.08m / 33'1"
Mass in Running Order (inc. tolerance)	980kg / 19.3cwt	1126kg / 22.2cwt Est	1174kg / 23.1cwt Est	1320kg / 26.0cwt Est
Maximum Technical Permissible Laden Mass (Lower limit)	1094kg / 21.5cwt	1247kg / 24.5cwt Est	1320kg / 26.0cwt Est	1476kg / 29.1cwt Est
Maximum Technical Permissible Laden Mass (Upper limit)	1200kg / 23.6cwt	1300kg / 25.6cwt	1400kg / 27.6cwt	1550kg / 30.5cwt
Total user Payload	114kg / 2.2cwt	121kg / 2.4cwt	146kg / 2.9cwt	156kg / 3.1cwt
Personal Effects	114kg / 2.2cwt	121kg / 2.4cwt	146kg / 2.9cwt	156kg / 3.1cwt
Options	0kg / 0.0cwt	0kg / 0.0cwt	0kg / 0.0cwt	0kg / 0.0cwt
Tyre Size	195/70 R15C 104 R	195/70 R15C 104 R	195/70 R15C 104 R	195/70 R15C 104 R
Tyre pressure at Lower limit MTPLM	3.4 bar / 49 psi	3.4 bar / 49 psi	3.5 bar / 51 psi	4.0 bar / 58 psi
Tyre pressure at Upper limit MTPLM	3.4 bar / 49 psi	3.4 bar / 49 psi	3.7 bar / 54 psi	4.2 bar / 61 psi
Static Load on Coupling Head	100kg	100kg	100kg	100kg
Thermal Insulation Grade	THREE	THREE	THREE	THREE
Bed Sizes				
Front Double	182cm x 180cm / 6'0" x 5'11"	202cm x 180cm / 6'8" x 5'11"	202cm x 128cm / 6'8" x 4'2"	202cm x 159cm / 6'8" x 5'3"
or Front Nearside Single	180cm x 63cm / 5'11" x 2'1"	190cm x 70cm / 6'3" x 2'3"		159cm x 70cm / 5'3" x 2'3"
and Front Offside Single	180cm x 63cm / 5'11" x 2'1"	180cm x 70cm / 5'11" x 2'3"		159cm x 70cm / 5'3" x 2'3"
Rear Double			194cm x 132cm / 6'4" x 4'4"	185cm x 133cm / 6'1" x 4'4"
Side Single (offside)				
Side Single (nearside)				
Side Bunk (offside)				
Side Bunk (nearside)				
Side Fixed Lower Bunk				
Side Fixed Upper Bunk				

Masses: The masses are calculated in accordance to EU regulation 1230 / 2012 and NCC code of practice 304.

The Mass in Running Order (MRO) comprises:

1. The mass of the empty caravan as supplied by Swift including loose items such as the hook-up cable, kit bag, entrance step, manuals etc.
2. 10kg allowance for LPG

The MRO is calculated with the fresh water tank, toilet flush tank and water heater empty. If you travel with water in the fresh water tank, toilet flush tank and the water heater the payload will reduce accordingly.

The personal effects is based on the number of berths and the length of the caravan and includes an allowance of 20kg for a leisure battery.

The Maximum Technical Laden Mass (MTPLM) is the maximum mass allowed when the caravan is fully laden.

WARNING: Under no circumstances should the MTPLM be exceeded

Major 4 EB	Major 6 TD	Quattro MB	Quattro FB
4	6	6	6
1	1	2	2
5.93m / 19'5"	5.93m / 19'5"	6.27m / 20'7"	6.27m / 20'7"
2.25m / 7'5"	2.25m / 7'5"	2.25m / 7'5"	2.25m / 7'5"
2.59m / 8'6"	2.59m / 8'6"	2.59m / 8'6"	2.59m / 8'6"
1.95m / 6'5"	1.95m / 6'5"	1.95m / 6'5"	1.95m / 6'5"
7.63m / 25'0"	7.63m / 25'0"	7.98m / 26'2"	7.98m / 26'2"
10.25m / 33'8"	10.25m / 33'8"	10.52m / 34'6"	10.52m / 34'6"
1351kg / 26.6cwt Est	1423kg / 28.0cwt Est	1485kg / 29.2cwt Est	1487kg / 29.3cwt Est
1508kg / 29.7cwt Est	1600kg / 31.5cwt Est	1665kg / 32.8cwt Est	1667kg / 32.8cwt Est
1550kg / 30.5cwt	1650kg / 32.5cwt	1800kg / 35.4cwt	1800kg / 35.4cwt
157kg / 3.1cwt	177kg / 3.5cwt	180kg / 3.5cwt	180kg / 3.5cwt
157kg / 3.1cwt	177kg / 3.5cwt	180kg / 3.5cwt	180kg / 3.5cwt
0kg / 0.0cwt	0kg / 0.0cwt	0kg / 0.0cwt	0kg / 0.0cwt
195/70 R15C 104 R	195/70 R15C 104 R	185/60 R15 88 H	185/60 R15 88 H
4.1 bar / 59 psi	4.4 bar / 64 psi	2.3 bar / 33 psi	2.3 bar / 33 psi
4.2 bar / 61 psi	4.5 bar / 65 psi	2.5 bar / 36 psi	2.5 bar / 36 psi
100kg	100kg	100kg	100kg
THREE	THREE	THREE	THREE
202cm x 159cm / 6'8" x 5'3"	202cm x 180cm / 6'8" x 5'11"	206cm x 131cm / 6'9" x 4'4"	202cm x 180cm / 6'8" x 5'11"
159cm x 70cm / 5'3" x 2'3"	180cm x 70cm / 5'11" x 2'3"		180cm x 70cm / 5'11" x 2'3"
159cm x 70cm / 5'3" x 2'3"	190cm x 70cm / 6'3" x 2'3"		190cm x 70cm / 6'3" x 2'3"
188cm x 133cm / 6'2" x 4'4"		200cm x 136cm / 6'4" x 4'6"	194cm x 132cm / 6'4" x 4'4"
		180cm x 62cm / 5'11" x 2'0"	180cm x 62cm / 5'11" x 2'0"
	180cm x 67cm / 5'11" x 2'2"		
		176cm x 59cm / 5'9" x 1'11"	176cm x 59cm / 5'9" x 1'11"
	176cm x 59cm / 5'9" x 1'11"		
	183cm x 57cm / 6'0" x 1'10"		
	183cm x 57cm / 6'0" x 1'10"		

Bed Sizes: Please note that the front double bed sizes quoted are for seating configurations without chest of drawers. The front double bed width for a layout with a chest of drawers fitted will be reduced by 0.4m (1'4") from that stated.

Awning sizes: Due to the varying awning designs and sizes the awning sizes given are approximate only. Specific awning sizes must be confirmed by your dealer or the awning manufacturer prior to purchase.

Est = Estimated weight or bed size

**The dimensions given are approximate due to slight variations in suspension ride heights, loading conditions and tyre pressures.

Customers should verify the actual dimensions of their touring caravan before committing to anything that could be impacted by these dimensions

Please note: Any dealer fit options will reduce the overall payload available to the user of the caravan.

If you require additional payload it is possible to upgrade the MTPLM to the upper limit. Please contact your caravan dealer for more information.

Sprite Grande Specification

Sprite Grande	Major 4 SB Grande	Quattro FB Grande	Quattro DB Grande
Berths	4	6	6
Axles	1	2	2
Internal Length (bed box height)	5.83m / 19' 2"	6.27m / 20' 7"	6.27m / 20' 7"
Overall Width**	2.46m / 8'1"	2.46m / 8'1"	2.46m / 8'1"
Overall Height (inc. TV Aerial)**	2.61m / 8'7"	2.59m / 8'6"	2.59m / 8'6"
Maximum Internal Headroom	1.95m / 6'5"	1.95m / 6'5"	1.95m / 6'5"
Overall Length**	7.54m / 24' 9"	7.98m / 26' 2"	7.98m / 26' 2"
Awning A / A dimension	10.20m / 33'6"	10.56m / 34'8"	10.56m / 34'8"
Mass in Running Order (inc. tolerance)	1404kg / 27.6cwt Est	1569kg / 30.9cwt Est	1567kg / 30.8cwt Est
Maximum Technical Permissible Laden Mass (Lower limit)	1560kg / 30.7cwt Est	1749kg / 34.4cwt Est	1747kg / 34.4cwt Est
Maximum Technical Permissible Laden Mass (Upper limit)	1650kg / 32.5cwt	1800kg / 35.4cwt	1800kg / 35.4cwt
Total user Payload	156kg / 3.1cwt	180kg / 3.5cwt	180kg / 3.5cwt
Personal Effects	156kg / 3.1cwt	180kg / 3.5cwt	180kg / 3.5cwt
Options	0kg / 0.0cwt	0kg / 0cwt	0kg / 0cwt
Tyre Size	195/70 R15C 104 R	185/60 R15 88 H	185/60 R15 88 H
Tyre pressure at Lower limit MTPLM	4.3 bar / 62 psi	2.4 bar / 35 psi	2.4 bar / 35 psi
Tyre pressure at Upper limit MTPLM	4.5 bar / 65 psi	2.5 bar / 36 psi	2.5 bar / 36 psi
Static Load on Coupling Head	100kg	100kg	100kg
Thermal Insulation Grade	THREE	THREE	THREE
Bed Sizes			
Front Double	225cm x 163cm / 7'4" x 5'4"	225cm x 180cm / 7'4" x 5'11"	225cm x 180cm / 7'4" x 5'11"
or Front Nearside Single	162cm x 73cm / 5'4" x 2'5"	179cm x 73cm / 5'10" x 2'5"	179cm x 73cm / 5'10" x 2'5"
and Front Offside Single	163cm x 73cm / 5'4" x 2'5"	180cm x 73cm / 5'11" x 2'5"	180cm x 73cm / 5'11" x 2'5"
Rear Double	185cm x 133cm / 6'1" x 4'4"	195cm x 136cm / 6'5" x 4'6"	
Side Double (offside)		190cm x 134cm / 6'3" x 4'5"	190cm x 134cm / 6'3" x 4'5"
Side Fixed Lower Bunk			182cm x 72cm / 6'0" x 2'4"
Side Fixed Upper Bunk			182cm x 72cm / 6'0" x 2'4"

Masses: The masses are calculated in accordance to EU regulation 1230 / 2012 and NCC code of practice 304.

The Mass in Running Order (MRO) comprises:

1. The mass of the empty caravan as supplied by Swift including loose items such as the hook-up cable, kit bag, entrance step, manuals etc.
2. 10kg allowance for LPG

The MRO is calculated with the fresh water tank, toilet flush tank and water heater empty. If you travel with water in the fresh water tank, toilet flush tank and the water heater the payload will reduce accordingly.

The personal effects is based on the number of berths and the length of the caravan and includes an allowance of 20kg for a leisure battery.

The Maximum Technical Laden Mass (MTPLM) is the maximum mass allowed when the caravan is fully laden.

WARNING: Under no circumstances should the MTPLM be exceeded

Quattro EB Grande
4
2
6.27m / 20'7"
2.46m / 8'1"
2.59m / 8'6"
1.95m / 6'5"
7.98m / 26'2"
10.56m / 34'8"
1558kg / 30.7cwt Est
1718kg 33.8cwt Est
1800kg / 35.4cwt
160kg / 3.1cwt
160kg / 3.1cwt
0kg / 0.0cwt
185/60 R15 88 H
2.4 bar / 35 psi
2.5 bar / 36 psi
100kg
THREE
225cm x 163cm / 7'4" x 5'4"
162cm x 73cm / 5'4" x 2'5"
180cm x 73cm / 5'11" x 2'5"
192cm x 143cm / 6'3" x 4'8"

Bed Sizes: Please note that the front double bed sizes quoted are for seating configurations without chest of drawers. The front double bed width for a layout with a chest of drawers fitted will be reduced by 0.4m (1'4") from that stated.

Awning sizes: Due to the varying awning designs and sizes the awning sizes given are approximate only. Specific awning sizes must be confirmed by your dealer or the awning manufacturer prior to purchase.

Est = Estimated weight or bed size

**The dimensions given are approximate due to slight variations in suspension ride heights, loading conditions and tyre pressures.

Customers should verify the actual dimensions of their touring caravan before committing to anything that could be impacted by these dimensions

Please note: Any dealer fit options will reduce the overall payload available to the user of the caravan.

If you require additional payload it is possible to upgrade the MTPLM to the upper limit. Please contact your caravan dealer for more information.

Sprite Exclusive Specification

Sprite Exclusive	Compact	Alpine 2	Alpine 4	Major 4 SB
Berths	2	2	4	4
Axles	1	1	1	1
Internal Length (bed box height)	3.66m / 12'0"	4.34m / 14'3"	4.83m / 15'10"	5.83m / 19'2"
Overall Width**	2.03m / 6'8"	2.25m / 7'5"	2.25m / 7'5"	2.25m / 7'5"
Overall Height (inc. TV Aerial)**	2.59m / 8'6"	2.59m / 8'6"	2.59m / 8'6"	2.59m / 8'6"
Maximum Internal Headroom	1.95m / 6'5"	1.95m / 6'5"	1.95m / 6'5"	1.95m / 6'5"
Overall Length**	5.37m / 17'7"	6.05m / 19'10"	6.53m / 21'5"	7.54m / 24'9"
Awning A / A dimension	7.95m / 26'1"	8.59m / 28'2"	10.02m / 32'10"	10.08m / 33'1"
Mass in Running Order (inc. tolerance)	995kg / 19.6cwt	1141kg / 22.5cwt Est	1189kg / 23.4cwt Est	1335kg / 26.3cwt Est
Maximum Technical Permissible Laden Mass (Lower limit)	1109kg / 21.8cwt	1262kg / 24.8cwt Est	1335kg / 26.3cwt Est	1491kg / 29.3cwt
Maximum Technical Permissible Laden Mass (Upper limit)	1200kg / 23.6cwt	1300kg / 25.6cwt	1400kg / 27.6cwt	1550kg / 30.5cwt
Total user Payload	114kg / 2.2cwt	121kg / 2.4cwt	146kg / 2.9cwt	156kg / 3.1cwt
Personal Effects	114kg / 2.2cwt	121kg / 2.4cwt	146kg / 2.9cwt	156kg / 3.1cwt
Options	0kg / 0.0cwt	0kg / 0.0cwt	0kg / 0.0cwt	0kg / 0.0cwt
Tyre Size	195/70 R15C 104 R	195/70 R15C 104 R	195/70 R15C 104 R	195/70 R15C 104 R
Tyre pressure at Lower limit MTPLM	3.4 bar / 49 psi	3.4 bar / 49 psi	3.5 bar / 51 psi	4.0 bar / 58 psi
Tyre pressure at Upper limit MTPLM	3.4 bar / 49 psi	3.4 bar / 49 psi	3.7 bar / 54 psi	4.2 bar / 61 psi
Static Load on Coupling Head	100kg	100kg	100kg	100kg
Thermal Insulation Grade	THREE	THREE	THREE	THREE
Bed Sizes				
Front Double	175cmx180cm / 5'9" x 5'11"	196cmx180cm / 6'5" x 5'11"	196cmx128cm / 6'5" x 4'2"	196cmx159cm / 6'5" x 5'3"
or Front Nearside Single	180cm x 60cm / 5'11" x 2'0"	190cm x 67cm / 6'3" x 2'2"		159cm x 67cm / 5'3" x 2'2"
and Front Offside Single	180cm x 60cm / 5'11" x 2'0"	180cm x 67cm / 5'11" x 2'2"		159cm x 67cm / 5'3" x 2'2"
Rear Double			194cmx132cm / 6'4" x 4'4"	185cm x 133cm / 6'1" x 4'4"
Side Single (offside)				
Side Single (nearside)				
Side Bunk (offside)				
Side Bunk (nearside)				
Side Fixed Lower Bunk				
Side Fixed Upper Bunk				

Masses: The masses are calculated in accordance to EU regulation 1230 / 2012 and NCC code of practice 304.

The Mass in Running Order (MRO) comprises:

1. The mass of the empty caravan as supplied by Swift including loose items such as the hook-up cable, kit bag, entrance step, manuals etc.
2. 10kg allowance for LPG

The MRO is calculated with the fresh water tank, toilet flush tank and water heater empty. If you travel with water in the fresh water tank, toilet flush tank and the water heater the payload will reduce accordingly.

The personal effects is based on the number of berths and the length of the caravan and includes an allowance of 20kg for a leisure battery.

The Maximum Technical Laden Mass (MTPLM) is the maximum mass allowed when the caravan is fully laden.

WARNING: Under no circumstances should the MTPLM be exceeded

Major 4 EB	Major 6 TD	Quattro MB	Quattro FB
4	6	6	6
1	1	2	2
5.93m / 19'5"	5.93m / 19'5"	6.27m / 20'7"	6.27m / 20'7"
2.25m / 7'5"	2.25m / 7'5"	2.25m / 7'5"	2.25m / 7'5"
2.59m / 8'6"	2.59m / 8'6"	2.59m / 8'6"	2.59m / 8'6"
1.95m / 6'5"	1.95m / 6'5"	1.95m / 6'5"	1.95m / 6'5"
7.63m / 25'0"	7.63m / 25'0"	7.98m / 26'2"	7.98m / 26'2"
10.25m / 33'8"	10.25m / 33'8"	10.52m / 34'6"	10.52m / 34'6"
1373kg / 27.0cwt Est	1445kg / 28.4cwt Est	1507kg / 29.7cwt Est	1509kg / 29.7cwt Est
1530kg / 30.1cwt Est	1622kg / 31.9cwt Est	1687kg / 33.2cwt Est	1689kg / 33.2cwt Est
1550kg / 30.5cwt	1650kg / 32.5cwt	1800kg / 35.4cwt	1800kg / 35.4cwt
157kg / 3.1cwt	177kg / 3.5cwt	180kg / 3.5cwt	180kg / 3.5cwt
157kg / 3.1cwt	177kg / 3.5cwt	180kg / 3.5cwt	180kg / 3.5cwt
0kg / 0.0cwt	0kg / 0.0cwt	0kg / 0.0cwt	0kg / 0.0cwt
195/70 R15C 104 R	195/70 R15C 104 R	185/60 R15 88 H	185/60 R15 88 H
4.1 bar / 59 psi	4.4 bar / 64 psi	2.3 bar / 33 psi	2.3 bar / 33 psi
4.2 bar / 61 psi	4.5 bar / 65 psi	2.5 bar / 36 psi	2.5 bar / 36 psi
100kg	100kg	100kg	100kg
THREE	THREE	THREE	THREE
196cmx159cm / 6'5" x 5'3"	196cmx180cm / 6'5" x 5'11"	203cmx127cm / 6'8" x 4'2"	196cmx180cm / 6'5" x 5'11"
159cm x 67cm / 5'3" x 2'2"	180cm x 67cm / 5'11" x 2'2"		180cm x 67cm / 5'11" x 2'2"
159cm x 67cm / 5'3" x 2'2"	190cm x 67cm / 6'3" x 2'2"		190cm x 67cm / 6'3" x 2'2"
188cm x 133cm / 6'2" x 4'4"		200cm x 136cm / 6'4" x 4'6"	194cm x 132cm / 6'4" x 4'4"
		180cm x 62cm / 5'11" x 2'0"	180cm x 62cm / 5'11" x 2'0"
	180cm x 67cm / 5'11" x 2'2"		
		176cm x 59cm / 5'9" x 1'11"	176cm x 59cm / 5'9" x 1'11"
	176cm x 59cm / 5'9" x 1'11"		
	183cm x 57cm / 6'0" x 1'10"		
	183cm x 57cm / 6'0" x 1'10"		

Bed Sizes: Please note that the front double bed sizes quoted are for seating configurations without chest of drawers. The front double bed width for a layout with a chest of drawers fitted will be reduced by 0.4m (1'4") from that stated.

Awning sizes: Due to the varying awning designs and sizes the awning sizes given are approximate only. Specific awning sizes must be confirmed by your dealer or the awning manufacturer prior to purchase.

Est = Estimated weight or bed size

**The dimensions given are approximate due to slight variations in suspension ride heights, loading conditions and tyre pressures.

Customers should verify the actual dimensions of their touring caravan before committing to anything that could be impacted by these dimensions

Please note: Any dealer fit options will reduce the overall payload available to the user of the caravan.

If you require additional payload it is possible to upgrade the MTPLM to the upper limit. Please contact your caravan dealer for more information.

Sprite Grande Exclusive Specification

Sprite Grande Exclusive	Major 4 SB Grande	Quattro FB Grande	Quattro DB Grande
Berths	4	6	6
Axles	1	2	2
Internal Length (bed box height)	5.83m / 19' 2"	6.27m / 20' 7"	6.27m / 20' 7"
Overall Width**	2.46m / 8'1"	2.46m / 8'1"	2.46m / 8'1"
Overall Height (inc. TV Aerial)**	2.61m / 8'7"	2.59m / 8'6"	2.59m / 8'6"
Maximum Internal Headroom	1.95m / 6'5"	1.95m / 6'5"	1.95m / 6'5"
Overall Length**	7.54m / 24' 9"	7.98m / 26' 2"	7.98m / 26' 2"
Awning A / A dimension	10.20m / 33'6"	10.56m / 34'8"	10.56m / 34'8"
Mass in Running Order (inc. tolerance)	1444kg / 28.4cwt Est	1603kg / 31.6cwt Est	1609kg / 31.7cwt Est
Maximum Technical Permissible Laden Mass (Lower limit)	1600kg / 31.5cwt Est	1783kg / 35.1cwt Est	1800kg / 35.4cwt Est
Maximum Technical Permissible Laden Mass (Upper limit)	1650kg / 32.5cwt	1800kg / 35.4cwt	1800kg / 35.4cwt
Total user Payload	156kg / 3.1cwt	180kg / 3.5cwt	191kg / 3.8cwt
Personal Effects	156kg / 3.1cwt	180kg / 3.5cwt	180kg / 3.5cwt
Options	0kg / 0.0cwt	0kg / 0cwt	0kg / 0cwt
Tyre Size	195/70 R15C 104 R	185/60 R15 88 H	185/60 R15 88 H
Tyre pressure at Lower limit MTPLM	4.4 bar / 64 psi	2.5 bar / 36 psi	2.5 bar / 36 psi
Tyre pressure at Upper limit MTPLM	4.5 bar / 65 psi	2.5 bar / 36 psi	2.5 bar / 36 psi
Static Load on Coupling Head	100kg	100kg	100kg
Thermal Insulation Grade	THREE	THREE	THREE
Bed Sizes			
Front Double	218cm x 163cm / 7'2" x 5'4"	218cm x 180cm / 7'2" x 5'11"	218cm x 180cm / 7'2" x 5'11"
or Front Nearside Single	162cm x 70cm / 5'4" x 2'4"	179cm x 70cm / 5'10" x 2'4"	179cm x 70cm / 5'10" x 2'4"
and Front Offside Single	163cm x 70cm / 5'4" x 2'4"	180cm x 70cm / 5'10" x 2'4"	180cm x 70cm / 5'10" x 2'4"
Rear Double	185cm x 133cm / 6'1" x 4'4"	195cm x 136cm / 6'5" x 4'6"	
Side Double (offside)		190cm x 134cm / 6'3" x 4'5"	190cm x 134cm / 6'3" x 4'5"
Side Fixed Lower Bunk			182cm x 72cm / 6'0" x 2'4"
Side Fixed Upper Bunk			182cm x 72cm / 6'0" x 2'4"

Masses: The masses are calculated in accordance to EU regulation 1230 / 2012 and NCC code of practice 304.

The Mass in Running Order (MRO) comprises:

1. The mass of the empty caravan as supplied by Swift including loose items such as the hook-up cable, kit bag, entrance step, manuals etc.
2. 10kg allowance for LPG

The MRO is calculated with the fresh water tank, toilet flush tank and water heater empty. If you travel with water in the fresh water tank, toilet flush tank and the water heater the payload will reduce accordingly.

The personal effects is based on the number of berths and the length of the caravan and includes an allowance of 20kg for a leisure battery.

The Maximum Technical Laden Mass (MTPLM) is the maximum mass allowed when the caravan is fully laden.

WARNING: Under no circumstances should the MTPLM be exceeded

Quattro EB Grande
4
2
6.27m / 20'7"
2.46m / 8'1"
2.59m / 8'6"
1.95m / 6'5"
7.98m / 26'2"
10.56m / 34'8"
1592kg / 31.3cwt Est
1752kg / 34.5cwt Est
1800kg / 35.4cwt
160kg / 3.1cwt
160kg / 3.1cwt
0kg / 0.0cwt
185/60 R15 88 H
2.4 bar / 35 psi
2.5 bar / 36 psi
100kg
THREE
218cm x 163cm / 7'2" x 5'4"
162cm x 70cm / 5'4" x 2'4"
180cm x 70cm / 5'10" x 2'4"
192cm x 143cm / 6'3" x 4'8"

Bed Sizes: Please note that the front double bed sizes quoted are for seating configurations without chest of drawers. The front double bed width for a layout with a chest of drawers fitted will be reduced by 0.4m (1'4") from that stated.

Awning sizes: Due to the varying awning designs and sizes the awning sizes given are approximate only. Specific awning sizes must be confirmed by your dealer or the awning manufacturer prior to purchase.

Est = Estimated weight or bed size

**The dimensions given are approximate due to slight variations in suspension ride heights, loading conditions and tyre pressures.

Customers should verify the actual dimensions of their touring caravan before committing to anything that could be impacted by these dimensions

Please note: Any dealer fit options will reduce the overall payload available to the user of the caravan.

If you require additional payload it is possible to upgrade the MTPLM to the upper limit. Please contact your caravan dealer for more information.

Challenger Specification

Challenger	480	560	580
Berths	2	4	4
Axles	1	1	1
Internal Length (bed box height)	4.98m / 16'4"	5.93m / 19'5"	5.93m / 19'5"
Overall Width**	2.28m / 7'6"	2.28m / 7'6"	2.28m / 7'6"
Overall Height (inc. TV Aerial)**	2.61m / 8'7"	2.61m / 8'7"	2.61m / 8'7"
Maximum Internal Headroom	1.95m / 6'5"	1.95m / 6'5"	1.95m / 6'5"
Overall Length**	6.68m / 21'11"	7.63m / 25'0"	7.63m / 25'0"
Awning A / A dimension	9.37m / 30'9"	10.32m / 33'10"	10.32m / 33'10"
Mass in Running Order (inc. tolerance)	1312kg / 25.8cwt Est	1482kg / 29.2cwt Est	1475kg / 29.0cwt Est
Maximum Technical Permissible Laden Mass (Lower limit)	1439kg / 28.3cwt Est	1650kg / 32.5cwt Est	1650kg / 32.5cwt Est
Maximum Technical Permissible Laden Mass (Upper limit)	1500kg / 29.5cwt	1650kg / 32.5cwt	1650kg / 32.5cwt
Total user Payload	127kg / 2.5cwt	168kg / 3.3cwt	175kg / 3.4cwt
Personal Effects	127kg / 2.5cwt	157kg / 3.1cwt	157kg / 3.1cwt
Options	0.0kg / 0.0cwt	0.0kg / 0.0cwt	0.0kg / 0.0cwt
Tyre Size	195/70 R15C 104 R	195/70 R15C 104 R	195/70 R15C 104 R
Tyre pressure at Lower limit MTPLM	57 psi / 3.9 bar	65 psi / 4.5 bar	65 psi / 4.5 bar
Tyre pressure at Upper limit MTPLM	59 psi / 4.1 bar	65 psi / 4.5 bar	65 psi / 4.5 bar
Static Load on Coupling Head	100kg	100kg	100kg
Thermal Insulation Grade	THREE	THREE	THREE
Bed Sizes			
Front Double	200cm x 186cm / 6'7" x 6'1"	200cm x 156m / 6'7" x 5'1"	200cm x 168cm / 6'7" x 5'6"
or Front Nearside Single and Front Offside Single	195cm x 67cm / 6'5" x 2'2"		
Rear Double		192cm x 133cm / 6'4" x 4'4"	185cm x 133cm / 6'1" x 4'4"

Masses: The masses are calculated in accordance to EU regulation 1230 / 2012 and NCC code of practice 304.

The Mass in Running Order (MRO) comprises:

1. The mass of the empty caravan as supplied by Swift including loose items such as the hook-up cable, kit bag, entrance step, manuals etc.
2. 10kg allowance for LPG

The MRO is calculated with the fresh water tank, toilet flush tank and water heater empty. If you travel with water in the fresh water tank, toilet flush tank and the water heater the payload will reduce accordingly.

The personal effects is based on the number of berths and the length of the caravan and includes an allowance of 20kg for a leisure battery.

The Maximum Technical Laden Mass (MTPLM) is the maximum mass allowed when the caravan is fully laden.

WARNING: Under no circumstances should the MTPLM be exceeded

650
4
2
6.27m / 20'7"
2.28m / 7'6"
2.61m / 8'7"
1.95m / 6'5"
7.98m / 26'2"
10.59m / 34'9"
1617kg / 31.8cwt Est
1777kg / 35.0cwt Est
2000kg / 39.4cwt
160kg / 3.1cwt
160kg / 3.1cwt
0.0kg / 0.0cwt
185/60 R15 88 H
36 psi / 2.5 bar
42 psi / 2.9 bar
100kg
THREE
200cm x 156cm / 6'7" x 5'1"
192cm x 133cm / 6'4" x 4'4"

Bed Sizes: Please note that the front double bed sizes quoted are for seating configurations without chest of drawers. The front double bed width for a layout with a chest of drawers fitted will be reduced by 0.4m (1'4") from that stated.

Awning sizes: Due to the varying awning designs and sizes the awning sizes given are approximate only. Specific awning sizes must be confirmed by your dealer or the awning manufacturer prior to purchase.

Est = Estimated weight or bed size

**The dimensions given are approximate due to slight variations in suspension ride heights, loading conditions and tyre pressures.

Customers should verify the actual dimensions of their touring caravan before committing to anything that could be impacted by these dimensions

Please note: Any dealer fit options will reduce the overall payload available to the user of the caravan.

If you require additional payload it is possible to upgrade the MTPLM to the upper limit. Please contact your caravan dealer for more information.

Challenger Grande Specification

Challenger Grande	560 L Grande	580 Grande	635 Grande
Berths	4	4	4
Axles	1	1	2
Internal Length (bed box height)	5.93m / 19'5"	5.93m / 19'5"	6.27m / 20'7"
Overall Width**	2.45m / 8'0"	2.45m / 8'0"	2.45m / 8'0"
Overall Height (inc. TV Aerial)**	2.61m / 8'7"	2.61m / 8'7"	2.59m / 8'6"
Maximum Internal Headroom	1.95m / 6'5"	1.95m / 6'5"	1.95m / 6'5"
Overall Length**	7.63m / 25'0"	7.63m / 25'0"	7.98m / 26'2"
Awning A / A dimension	10.32m / 33'10"	10.32m / 33'10"	10.59m / 34'9"
Mass in Running Order (inc. tolerance)	1549kg / 30.5cwt Est	1515kg / 29.8cwt Est	1690kg / 33.3cwt Est
Maximum Technical Permissible Laden Mass (Lower limit)	1706kg / 33.6cwt Est	1672kg / 32.9cwt Est	1850kg / 36.4cwt Est
Maximum Technical Permissible Laden Mass (Upper limit)	1750kg / 34.4cwt	1750kg / 34.4cwt	2000kg / 39.4cwt
Total user Payload	157kg / 3.1cwt	160kg / 3.1cwt	167kg / 3.3cwt
Personal Effects	157kg / 3.1cwt	157kg / 3.1cwt	160kg / 3.1cwt
Options	0.0kg / 0.0cwt	0.0kg / 0.0cwt	0.0kg / 0.0cwt
Tyre Size	195/70 R15C 104 R	195 / 70 R15C 104 R	185/60 R15 88 H
Tyre pressure at Lower limit MTPLM	65 psi / 4.5 bar	65 psi / 4.5 bar	38 psi / 2.6 bar
Tyre pressure at Upper limit MTPLM	65 psi / 4.5 bar	65 psi / 4.5 bar	42 psi / 2.9 bar
Static Load on Coupling Head	100kg	100kg	100kg
Thermal Insulation Grade	THREE	THREE	THREE
Bed Sizes			
Front Double	194cm x 122cm / 6'4" x 4'0"	218cm x 168cm / 7'2" x 5'6"	218cm x 158cm / 7'2" x 5'2"
Front Single Offside			
Side Fixed Lower Bunk			
Side Fixed Upper Bunk			
Rear Double	192cm x 143cm / 6'4" x 4'8"	187cm x 133cm / 6'2" x 4'4"	187cm x 133cm / 6'2" x 4'4"

Masses: The masses are calculated in accordance to EU regulation 1230 / 2012 and NCC code of practice 304.

The Mass in Running Order (MRO) comprises:

1. The mass of the empty caravan as supplied by Swift including loose items such as the hook-up cable, kit bag, entrance step, manuals etc.
2. 10kg allowance for LPG

The MRO is calculated with the fresh water tank, toilet flush tank and water heater empty. If you travel with water in the fresh water tank, toilet flush tank and the water heater the payload will reduce accordingly.

The personal effects is based on the number of berths and the length of the caravan and includes an allowance of 20kg for a leisure battery.

The Maximum Technical Laden Mass (MTPLM) is the maximum mass allowed when the caravan is fully laden.

WARNING: Under no circumstances should the MTPLM be exceeded

650 Grande	670 Grande
4	6
2	2
6.27m / 20'7"	6.27m / 20'7"
2.45m / 8'0"	2.45m / 8'0"
2.59m / 8'6"	2.59m / 8'6"
1.95m / 6'5"	1.95m / 6'5"
7.98m / 26'2"	7.98m / 26'2"
10.59m / 34'9"	10.59m / 34'9"
1664kg / 32.8cwt Est	1683kg / 33.1cwt Est
1824kg / 35.9cwt Est	1863kg / 36.7cwt Est
2000kg / 39.4cwt	2000kg / 39.4cwt
160kg / 3.1cwt	180kg / 3.5cwt
160kg / 3.1cwt	180kg / 3.5cwt
0.0kg / 0.0cwt	0.0kg / 0.0cwt
185/60 R15 88 H	185/60 R15 88 H
38 psi / 2.6 bar	38 psi / 2.6 bar
42 psi / 2.9 bar	42 psi / 2.9 bar
100kg	100kg
THREE	THREE
194cm x 122cm / 6'4" x 4'0"	218cm x 168cm / 7'2" x 5'6"
	163cm x 70cm / 5'4" x 2'4"
	183cm x 57cm / 6'0" x 1'10"
	183cm x 57cm / 6'0" x 1'10"
192cm x 143cm / 6'4" x 4'8"	186cm x 122cm / 6'1" x 4'0"

Bed Sizes: Please note that the front double bed sizes quoted are for seating configurations without chest of drawers. The front double bed width for a layout with a chest of drawers fitted will be reduced by 0.4m (1'4") from that stated.

Awning sizes: Due to the varying awning designs and sizes the awning sizes given are approximate only. Specific awning sizes must be confirmed by your dealer or the awning manufacturer prior to purchase.

Est = Estimated weight or bed size

**The dimensions given are approximate due to slight variations in suspension ride heights, loading conditions and tyre pressures.

Customers should verify the actual dimensions of their touring caravan before committing to anything that could be impacted by these dimensions

Please note: Any dealer fit options will reduce the overall payload available to the user of the caravan.

If you require additional payload it is possible to upgrade the MTPLM to the upper limit. Please contact your caravan dealer for more information.

Challenger Exclusive Specification

Challenger Exclusive	480	560	580
Berths	2	4	4
Axles	1	1	1
Internal Length (bed box height)	4.98m / 16'4"	5.93m / 19'5"	5.93m / 19'5"
Overall Width**	2.28m / 7'6"	2.28m / 7'6"	2.28m / 7'6"
Overall Height (inc. TV Aerial)**	2.61m / 8'7"	2.61m / 8'7"	2.61m / 8'7"
Maximum Internal Headroom	1.95m / 6'5"	1.95m / 6'5"	1.95m / 6'5"
Overall Length**	6.68m / 21'11"	7.63m / 25'0"	7.63m / 25'0"
Awning A / A dimension	9.37m / 30'9"	10.32m / 33'10"	10.32m / 33'10"
Mass in Running Order (inc. tolerance)	1320kg / 26.0cwt Est	1490kg / 29.3cwt Est	1483kg / 29.2cwt Est
Maximum Technical Permissible Laden Mass (Lower limit)	1447kg / 28.5cwt Est	1650kg / 32.5cwt Est	1650kg / 32.5cwt Est
Maximum Technical Permissible Laden Mass (Upper limit)	1500kg / 29.5cwt	1650kg / 32.5cwt	1650kg / 32.5cwt
Total user Payload	127kg / 2.5cwt	160kg / 3.1cwt	167kg / 3.3cwt
Personal Effects	127kg / 2.5cwt	157kg / 3.1cwt	157kg / 3.1cwt
Options	0kg / 0cwt	0kg / 0cwt	0kg / 0cwt
Tyre Size	195/70 R15C 104 R	195/70 R15C 104 R	195/70 R15C 104 R
Tyre pressure at Lower limit MTPLM	3.9 bar / 57 psi	4.5 bar / 65 psi	4.5 bar / 65 psi
Tyre pressure at Upper limit MTPLM	4.1 bar / 59 psi	4.5 bar / 65 psi	4.5 bar / 65 psi
Static Load on Coupling Head	100kg	100kg	100kg
Thermal Insulation Grade	THREE	THREE	THREE
Bed Sizes			
Front Double	200cm x 186cm / 6'7" x 6'1"	200cm x 156cm / 6'7" x 5'1"	200cm x 168cm / 6'7" x 5'6"
or Front Nearside Single	195cm x 67cm / 6'5" x 2'2"		
and Front Offside Single	186cm x 67cm / 6'1" x 2'2"		
Rear Double		192cm x 133cm / 6'4" x 4'4"	185cm x 133cm / 6'1" x 4'4"

650
4
2
6.27m / 20'7"
2.28m / 7'6"
2.61m / 8'7"
1.95m / 6'5"
7.98m / 26'2"
10.59m / 34'9"
1625kg / 32.0cwt Est
1785kg / 35.1cwt Est
2000kg / 39.4cwt
160kg / 3.1cwt
160kg / 3.1cwt
0kg / 0cwt
185/60 R15 88 H
2.5 bar / 36 psi
2.9 bar / 42 psi
100kg
THREE
200cm x 156cm / 6'7" x 5'1"
192cm x 133cm / 6'4" x 4'4"

Challenger Grande Exclusive Specification

Challenger Grande Exclusive	560 L Grande	580 Grande	635 Grande
Berths	4	4	4
Axles	1	1	2
Internal Length (bed box height)	5.93m / 19'5"	5.93m / 19'5"	6.27m / 20'7"
Overall Width**	2.45m / 8'0"	2.45m / 8'0"	2.45m / 8'0"
Overall Height (inc. TV Aerial)**	2.61m / 8'7"	2.61m / 8'7"	2.59m / 8'6"
Maximum Internal Headroom	1.95m / 6'5"	1.95m / 6'5"	1.95m / 6'5"
Overall Length**	7.63m / 25'0"	7.63m / 25'0"	7.98m / 26'2"
Awning A / A dimension	10.32m / 33'10"	10.32m / 33'10"	10.59m / 34'9"
Mass in Running Order (inc. tolerance)	1556kg / 30.6cwt Est	1522kg / 30.0cwt Est	1697kg / 33.4cwt Est
Maximum Technical Permissible Laden Mass (Lower limit)	1713kg / 33.7cwt Est	1679kg / 33.1cwt Est	1857kg / 36.6cwt Est
Maximum Technical Permissible Laden Mass (Upper limit)	1750kg / 34.4cwt	1750kg / 34.4cwt	2000kg / 39.4cwt
Total user Payload	157kg / 3.1cwt	157kg / 3.1cwt	160kg / 3.1cwt
Personal Effects	157kg / 3.1cwt	157kg / 3.1cwt	160kg / 3.1cwt
Options	0.0kg / 0cwt	0.0kg / 0cwt	0.0kg / 0cwt
Tyre Size	195/70 R15C 104 R	195/70 R15C 104 R	185/60 R15 88 H
Tyre pressure at Lower limit MTPLM	4.5 bar / 65 psi	4.5 bar / 65 psi	2.6 bar / 38 psi
Tyre pressure at Upper limit MTPLM	4.5 bar / 65 psi	4.5 bar / 65 psi	2.9 bar / 42 psi
Static Load on Coupling Head	100kg	100kg	100kg
Thermal Insulation Grade	THREE	THREE	THREE
Bed Sizes			
Front Double	194cm x 122cm / 6'4" x 4'0"	218cm x 168cm / 7'2" x 5'6"	218cm x 158cm / 7'2" x 5'2"
Front Single Offside			
Side Fixed Lower Bunk			
Side Fixed Upper Bunk			
Rear Double	192cm x 143cm / 6'4" x 4'8"	187cm x 133cm / 6'2" x 4'4"	187cm x 133cm / 6'2" x 4'4"

Masses: The masses are calculated in accordance to EU regulation 1230 / 2012 and NCC code of practice 304.

The Mass in Running Order (MRO) comprises:

1. The mass of the empty caravan as supplied by Swift including loose items such as the hook-up cable, kit bag, entrance step, manuals etc.
2. 10kg allowance for LPG

The MRO is calculated with the fresh water tank, toilet flush tank and water heater empty. If you travel with water in the fresh water tank, toilet flush tank and the water heater the payload will reduce accordingly.

The personal effects is based on the number of berths and the length of the caravan and includes an allowance of 20kg for a leisure battery.

The Maximum Technical Laden Mass (MTPLM) is the maximum mass allowed when the caravan is fully laden.

WARNING: Under no circumstances should the MTPLM be exceeded

650 Grande	670 Grande
4	6
2	2
6.27m / 20'7"	6.27m / 20'7"
2.45m / 8'0"	2.45m / 8'0"
2.59m / 8'6"	2.59m / 8'6"
1.95m / 6'5"	1.95m / 6'5"
7.98m / 26'2"	7.98m / 26'2"
10.59m / 34'9"	10.59m / 34'9"
1671kg / 32.9cwt Est	1690kg / 33.3cwt Est
1831kg / 36.0cwt Est	1870kg / 36.8cwt Est
2000kg / 39.4cwt	2000kg / 39.4cwt
160kg / 3.1cwt	180kg / 3.5cwt
160kg / 3.1cwt	180kg / 3.5cwt
0.0kg / 0cwt	0kg / 0cwt
185/60 R15 88 H	185/60 R15 88 H
2.6 bar / 38 psi	2.6 bar / 38 psi
2.9 bar / 42 psi	2.9 bar / 42 psi
100kg	100kg
THREE	THREE
194cm x 122cm / 6'4" x 4'0"	218cm x 168cm / 7'2" x 5'6"
	163cm x 70cm / 5'4" x 2'4"
	183cm x 57cm / 6'0" x 1'10"
	183cm x 57cm / 6'0" x 1'10"
192cm x 143cm / 6'4" x 4'8"	186cm x 122cm / 6'1" x 4'0"

Bed Sizes: Please note that the front double bed sizes quoted are for seating configurations without chest of drawers. The front double bed width for a layout with a chest of drawers fitted will be reduced by 0.4m (1'4") from that stated.

Awning sizes: Due to the varying awning designs and sizes the awning sizes given are approximate only. Specific awning sizes must be confirmed by your dealer or the awning manufacturer prior to purchase.

Est = Estimated weight or bed size

**The dimensions given are approximate due to slight variations in suspension ride heights, loading conditions and tyre pressures.

Customers should verify the actual dimensions of their touring caravan before committing to anything that could be impacted by these dimensions

Please note: Any dealer fit options will reduce the overall payload available to the user of the caravan.

If you require additional payload it is possible to upgrade the MTPLM to the upper limit. Please contact your caravan dealer for more information.

Elegance Grande Specification

Elegance Grande	780	835	845
Berths	4	4	4
Axles	1	2	2
Internal Length (bed box height)	5.95m / 19' 6"	6.36m / 20'10"	6.36m / 20'10"
Overall Width*	2.45m / 8'0"	2.45m / 8'0"	2.45m / 8'0"
Overall Height (inc. TV Aerial)*	2.61m / 8' 7"	2.59m / 8'6"	2.59m / 8'6"
Maximum Internal Headroom	1.95m / 6'5"	1.95m / 6'5"	1.95m / 6'5"
Overall Length*	7.57m / 24' 10"	7.98m / 26'2"	7.98m / 26'2"
Awning A / A dimension	10.08m / 33'1"	10.49m / 34'5"	10.49m / 34'5"
Mass in Running Order (inc. tolerance)	1701kg / 33.5cwt Est	1898kg / 37.4cwt Est	1888kg / 37.2cwt Est
Maximum Technical Permissible Laden Mass (Lower limit)	1900kg / 37.4cwt Est	2099kg / 41.3cwt Est	2089kg / 41.1cwt Est
Maximum Technical Permissible Laden Mass (Upper limit)	1900kg / 37.4cwt	2250kg / 44.3cwt	2250kg / 44.3cwt
Total user Payload	199kg / 3.9cwt	201kg / 4.0cwt	201kg / 4.0cwt
Personal Effects	156kg / 3.1cwt	160kg / 3.1cwt	160kg / 3.1cwt
Options	41kg / 0.8cwt	41kg / 0.8cwt	41kg / 0.8cwt
Tyre Size	215/60 R17 109	215/45 R17 91	215/45 R17 91
Tyre pressure at Lower limit MTPLM	65 psi / 4.5 bar	46 psi / 3.2 bar	46 psi / 3.2 bar
Tyre pressure at Upper limit MTPLM	65 psi / 4.5 bar	49 psi / 3.4 bar	49 psi / 3.4 bar
Static Load on Coupling Head	100kg	120kg	120kg
Thermal Insulation Grade	THREE	THREE	THREE
Bed Sizes			
Front Double	218cm x 126cm / 72" x 42"	218cm x 126cm / 72" x 42"	218cm x 126cm / 72" x 42"
Rear Double	191cm x 133cm x 63" x 44"	191cm x 133cm / 63" x 44"	191cm x 133cm / 63" x 44"

Masses: The masses are calculated in accordance to EU regulation 1230 / 2012 and NCC code of practice 304.

The Mass in Running Order (MRO) comprises:

1. The mass of the empty caravan as supplied by Swift including loose items such as the hook-up cable, kit bag, entrance step, manuals etc.
2. 10kg allowance for LPG

The MRO is calculated with the fresh water tank, toilet flush tank and water heater empty. If you travel with water in the fresh water tank, toilet flush tank and the water heater the payload will reduce accordingly.

The personal effects is based on the number of berths and the length of the caravan and includes an allowance of 20kg for a leisure battery.

The Maximum Technical Laden Mass (MTPLM) is the maximum mass allowed when the caravan is fully laden.

WARNING: Under no circumstances should the MTPLM be exceeded

850	860
4	4
2	2
6.36m / 20'10"	6.36m / 20'10"
2.45m / 8'0"	2.45m / 8'0"
2.59m / 8'6"	2.59m / 8'6"
1.95m / 6'5"	1.95m / 6'5"
7.98m / 26'2"	7.98m / 26'2"
10.49m / 34'5"	10.49m / 34'5"
1888kg / 37.2cwt Est	1842kg / 36.3cwt Est
2089kg / 41.1cwt Est	2043kg / 40.2cwt Est
2250kg / 44.3cwt	2250kg / 44.3cwt
201kg / 4.0cwt	201kg / 4.0cwt
160kg / 3.1cwt	160kg / 3.1cwt
41kg / 0.8cwt	41kg / 0.8cwt
215/45 R17 91	215/45 R17 91
46 psi / 3.2 bar	45 psi / 3.1 bar
49 psi / 3.4 bar	49 psi / 3.4 bar
120kg	120kg
THREE	THREE
194cm x 122cm / 6'4" x 4'0"	194cm x 122cm / 6'4" x 4'0"
191cm x 143cm / 6'3" x 4'8"	191cm x 143cm / 6'3" x 4'8"

Bed Sizes: Please note that the front double bed sizes quoted are for seating configurations without chest of drawers. The front double bed width for a layout with a chest of drawers fitted will be reduced by 0.4m (1'4") from that stated.

Awning sizes: Due to the varying awning designs and sizes the awning sizes given are approximate only. Specific awning sizes must be confirmed by your dealer or the awning manufacturer prior to purchase.

Est = Estimated weight or bed size

**The dimensions given are approximate due to slight variations in suspension ride heights, loading conditions and tyre pressures.

Customers should verify the actual dimensions of their touring caravan before committing to anything that could be impacted by these dimensions

Please note: Any dealer fit options will reduce the overall payload available to the user of the caravan.

If you require additional payload it is possible to upgrade the MTPLM to the upper limit. Please contact your caravan dealer for more information.

Wiring Diagrams - Road Lighting

Basecamp

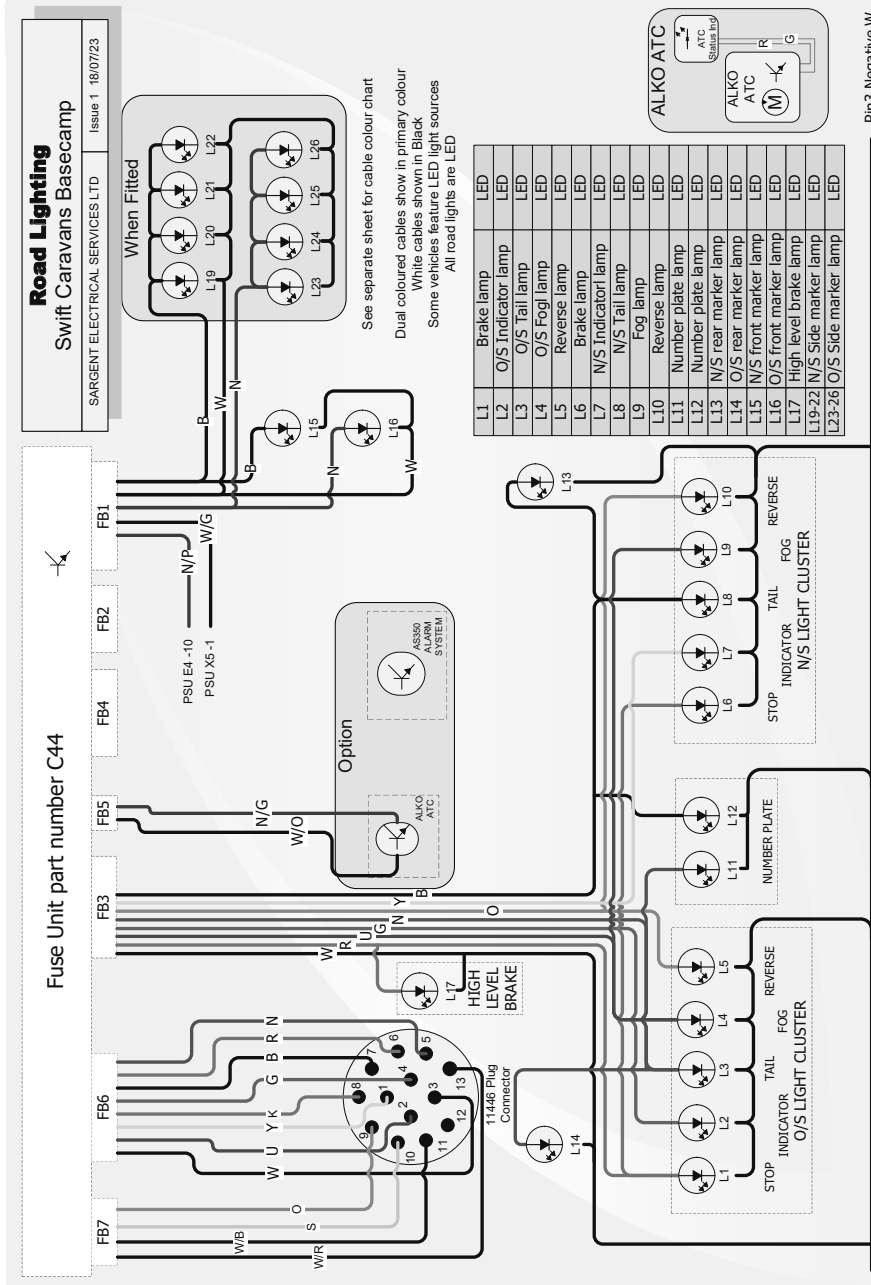

Copyright Sargent Electrical Services Ltd. 2023 all rights reserved. Subject to change without prior notice.

Wiring Diagrams - Road Lighting

Sprite, Sprite Grande, Challenger, Challenger Grande and Elegance Grande

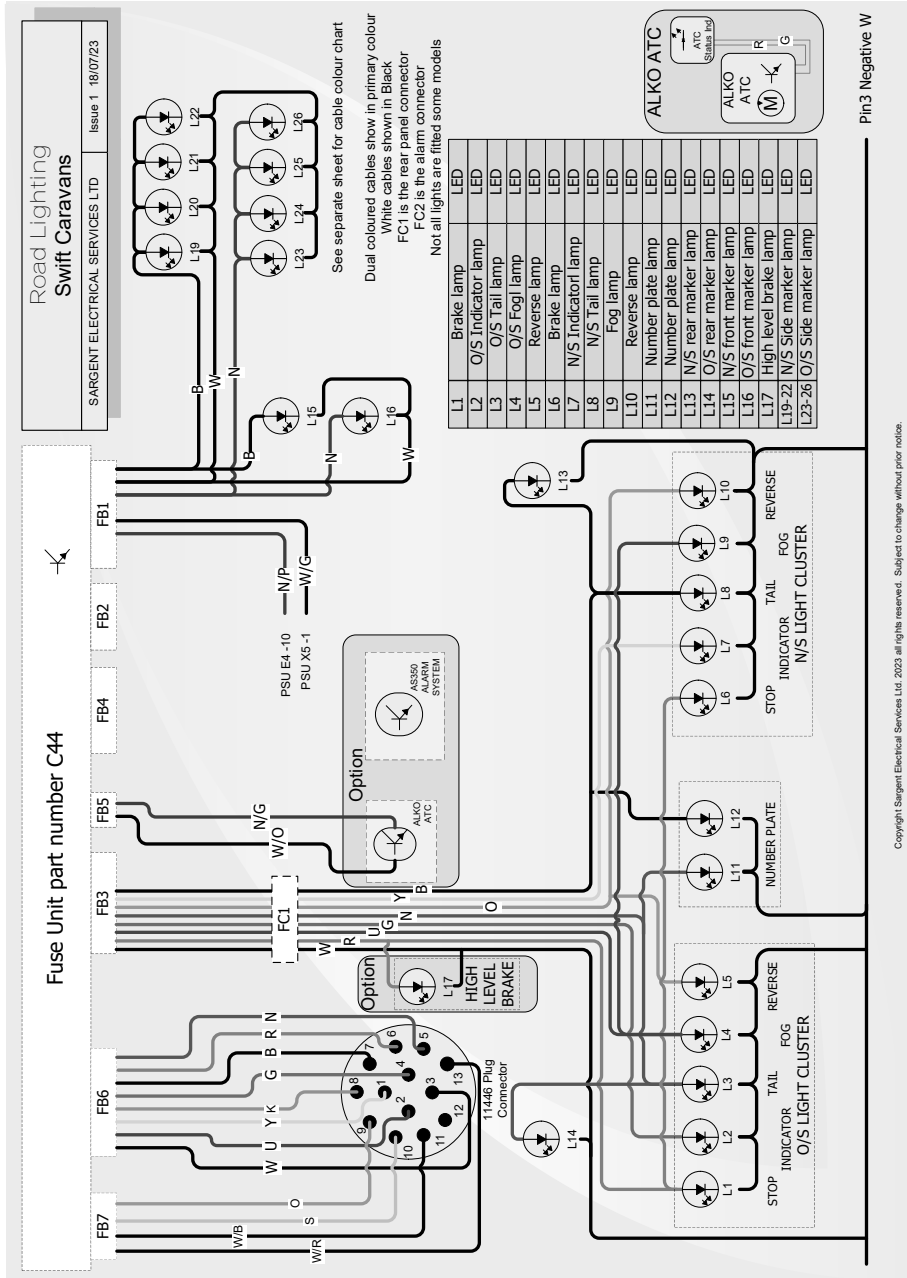

Wiring Diagrams - Consumer Circuits

Basecamp

Consumer Circuits - Basecamp
 Swift Caravans Basecamp
 SARGENT ELECTRICAL SERVICES LTD Issue 1 18/07/23

See separate sheet for cable colour chart
 Dual coloured cables show in primary colour
 White cables shown in Black 12v socket positions dependent on layout

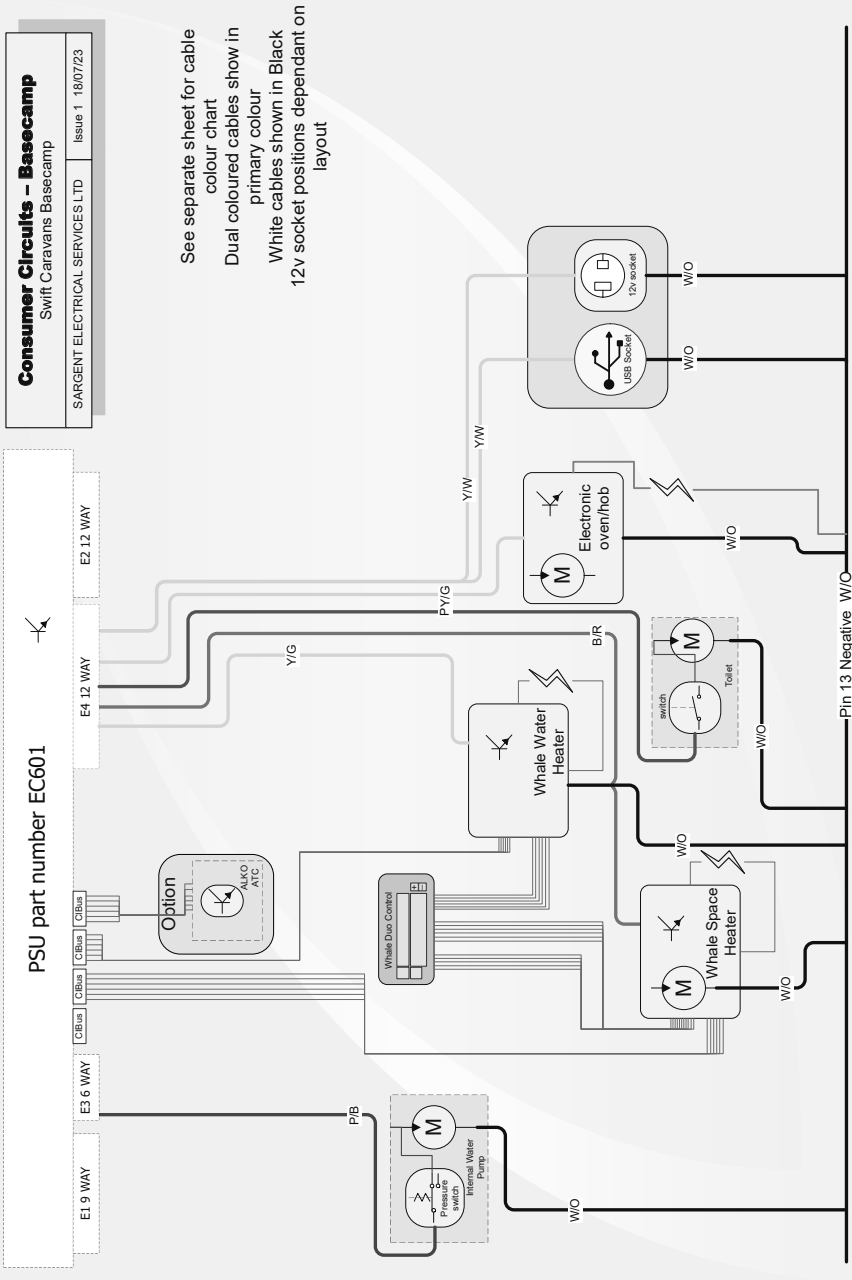

Copyright Sargent Electrical Services Ltd. 2023. All rights reserved. Subject to change without prior notice.

Wiring Diagrams - Consumer Circuits

Floor with Combi heating: Sprite and Sprite Grande

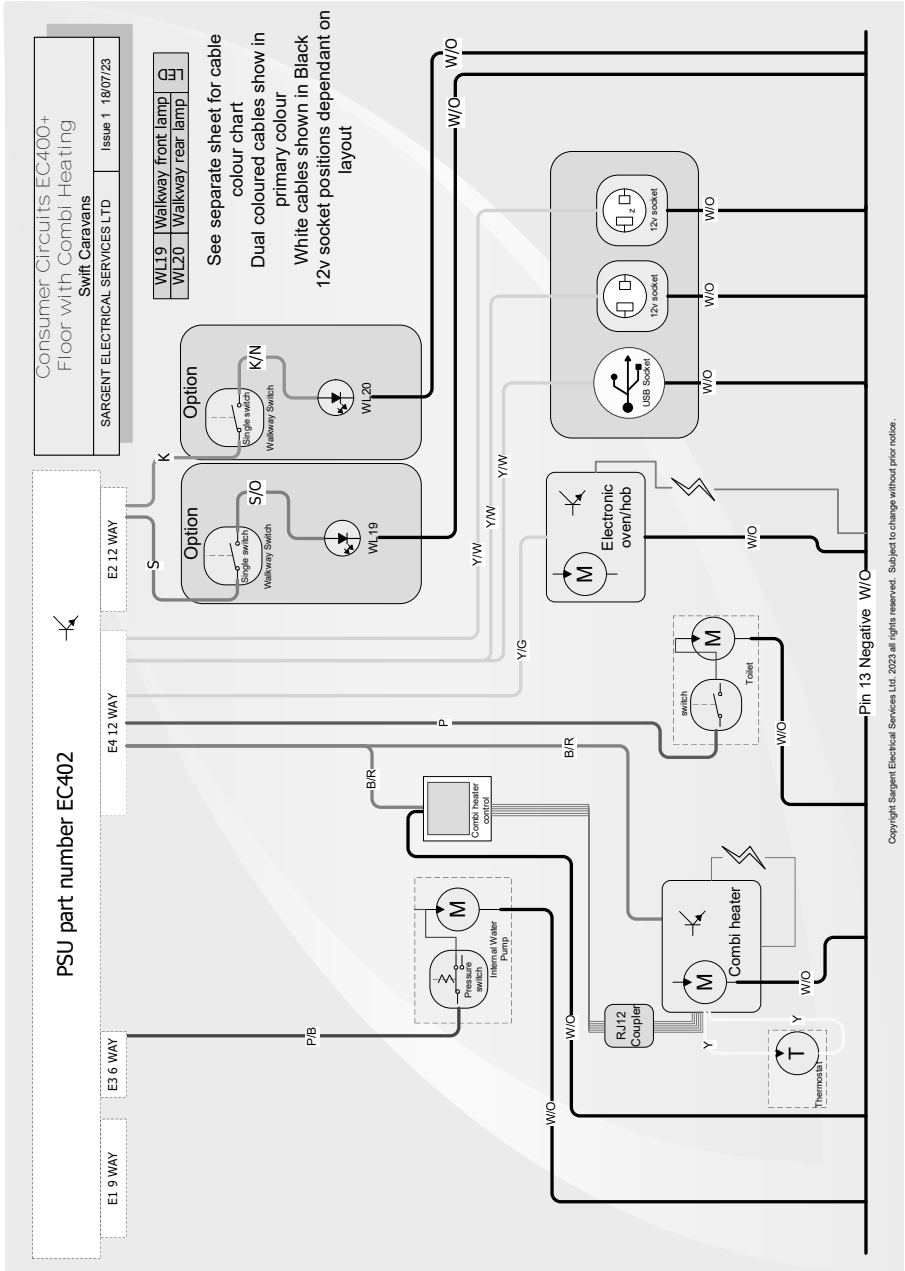

Wiring Diagrams - Consumer Circuits

Floor with Alde heating - Challenger and Challenger Grande

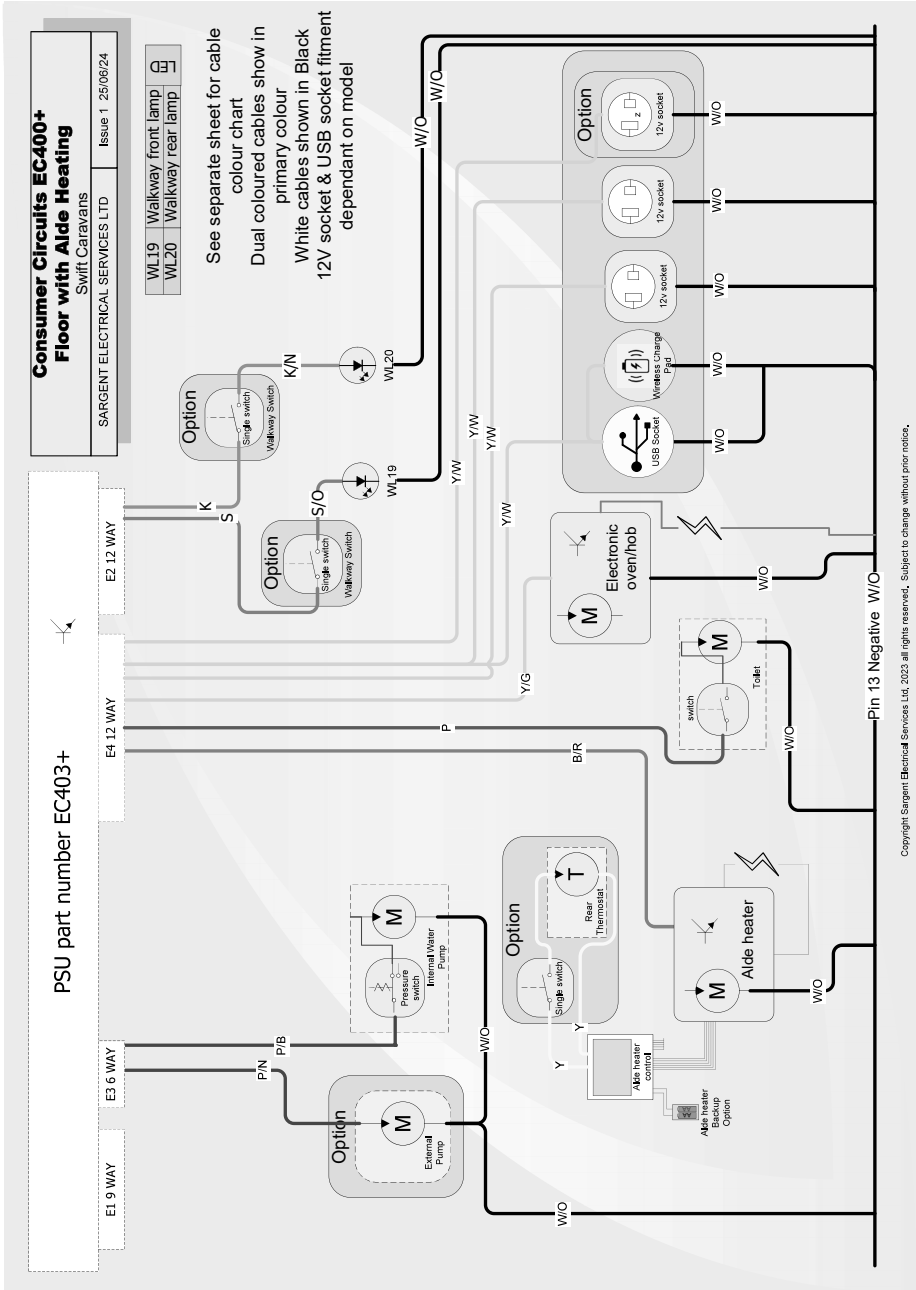

Wiring Diagrams - Consumer Circuits

Floor with Alde heating - Elegance Grande

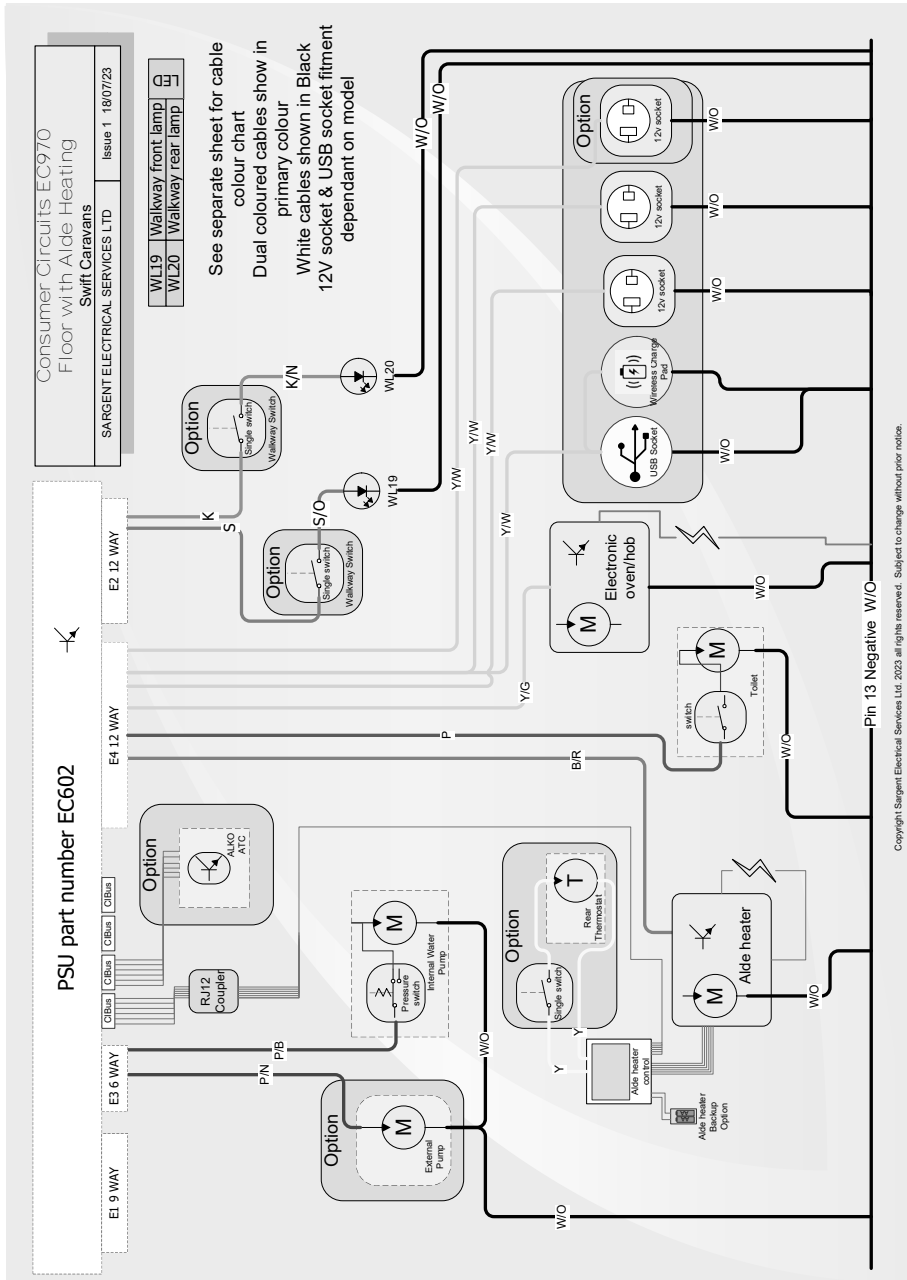

Wiring Diagrams - Consumer Circuits - Roof

Basecamp

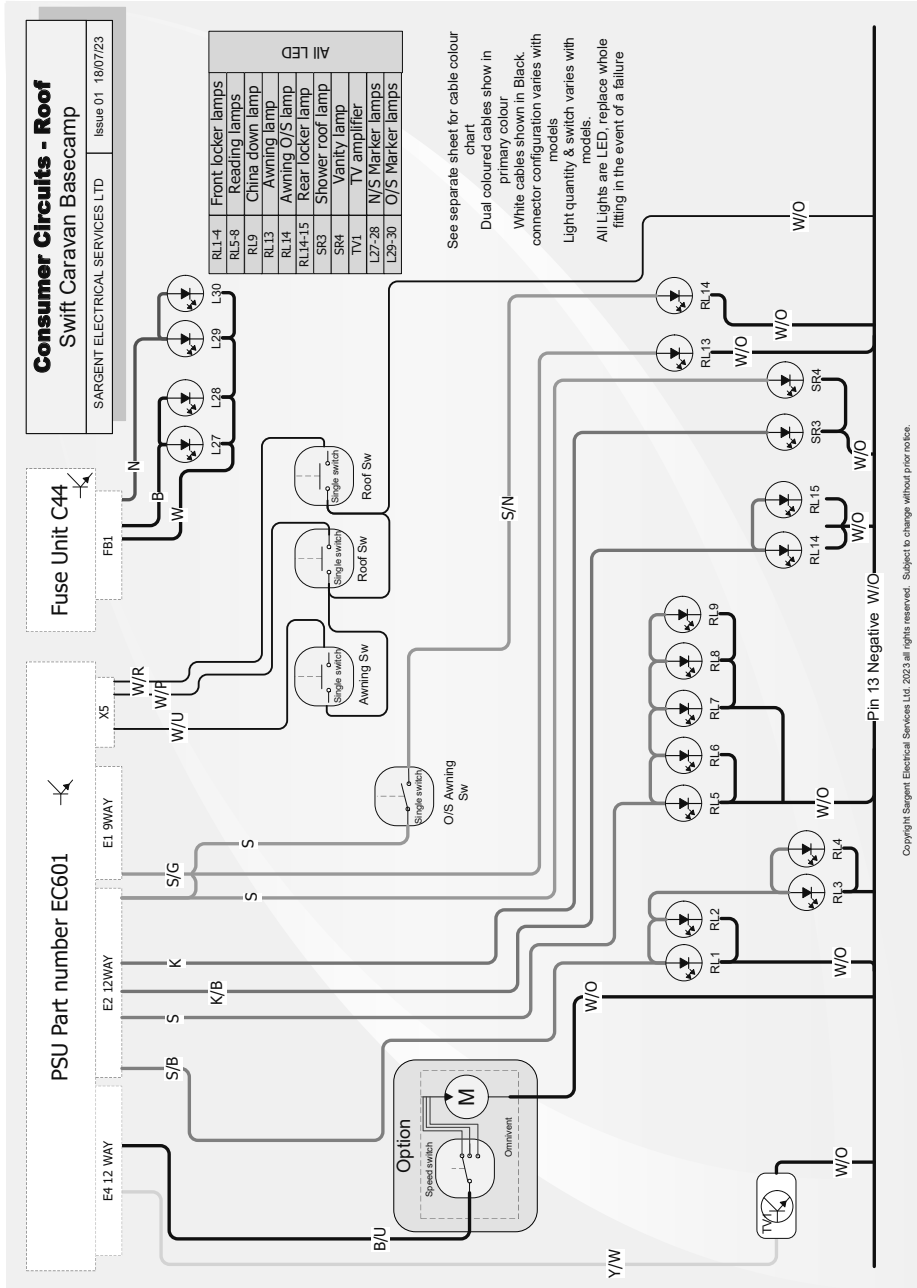

Wiring Diagrams - Consumer Circuits - Roof

Sprite, Sprite Grande, Challenger and Challenger Grande

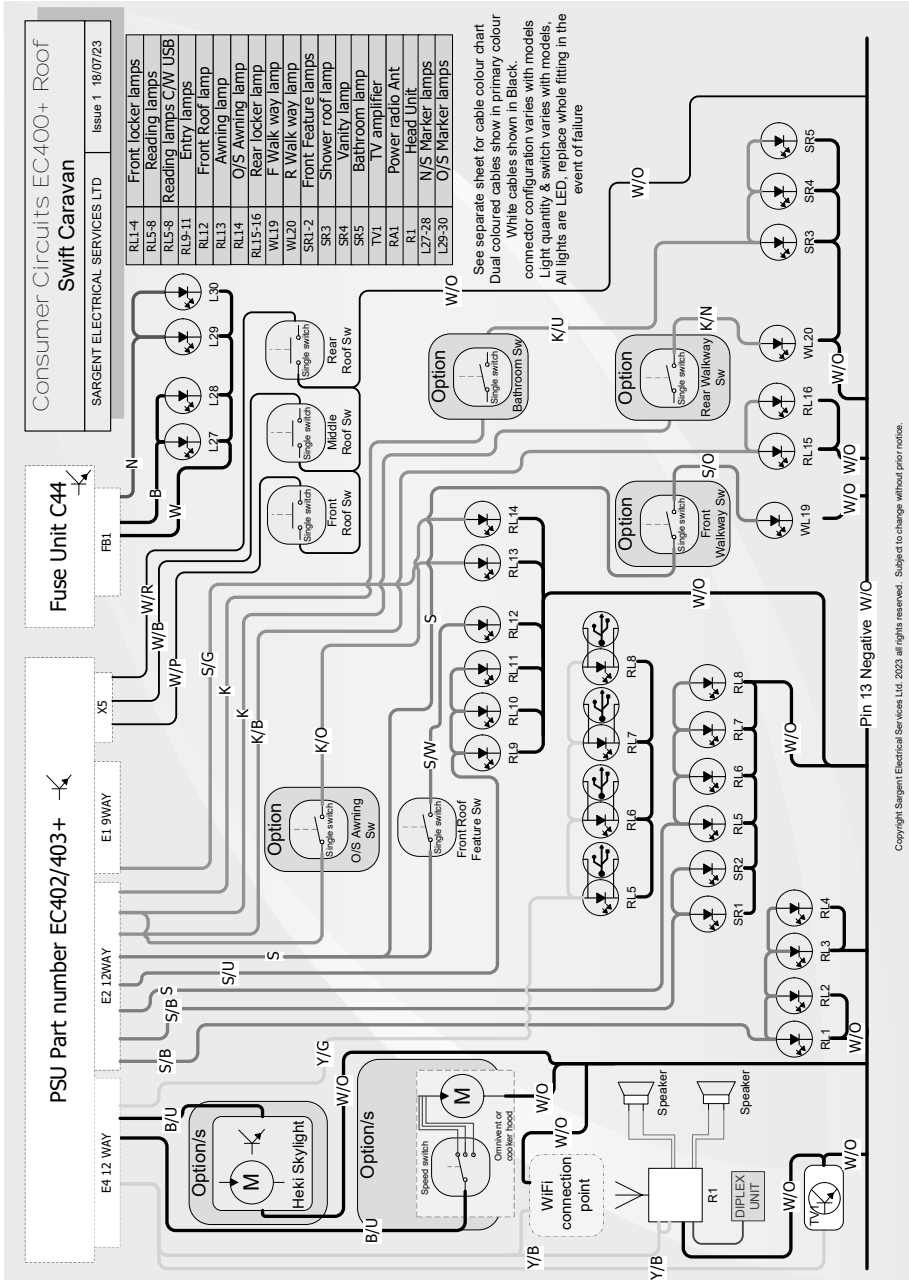

Wiring Diagrams - Consumer Circuits - Roof

Elegance Grande

Consumer Circuits EC970 Roof Swift Caravan

SARGENT ELECTRICAL SERVICES LTD Issue 1 19/07/23

RL1-4	Front locker lamps
RL5-8	Reading lamps C/W USB
RL9-11	Entry lamps
RL12	Front Roof lamp
RL13	Awning lamp
RL14	O/S Awning lamp
RL15-16	Rear locker lamp
RL17-18	Splashback lamp
WL19	F Walk way lamp
WL20	R Walk way lamp
SR1-2	Front Feature lamps
SR3	Shower roof lamp
SR4	Vanity lamp
SR5	Bathroom lamp
SR6	Mirror lamp
SR7	Wardrobe lamp
TV1	TV amplifier
RA1	Power radio Ant
RI	Head Unit
L27-28	N/S Marker lamps
L29-30	O/S Marker lamps

See separate sheet for cable colour chart
 Dual coloured cables show in primary colour
 White cables shown in Black.
 connector configuration varies with models
 Light quantity & switch varies with models
 All lights are LED, replace whole fitting in the event of failure

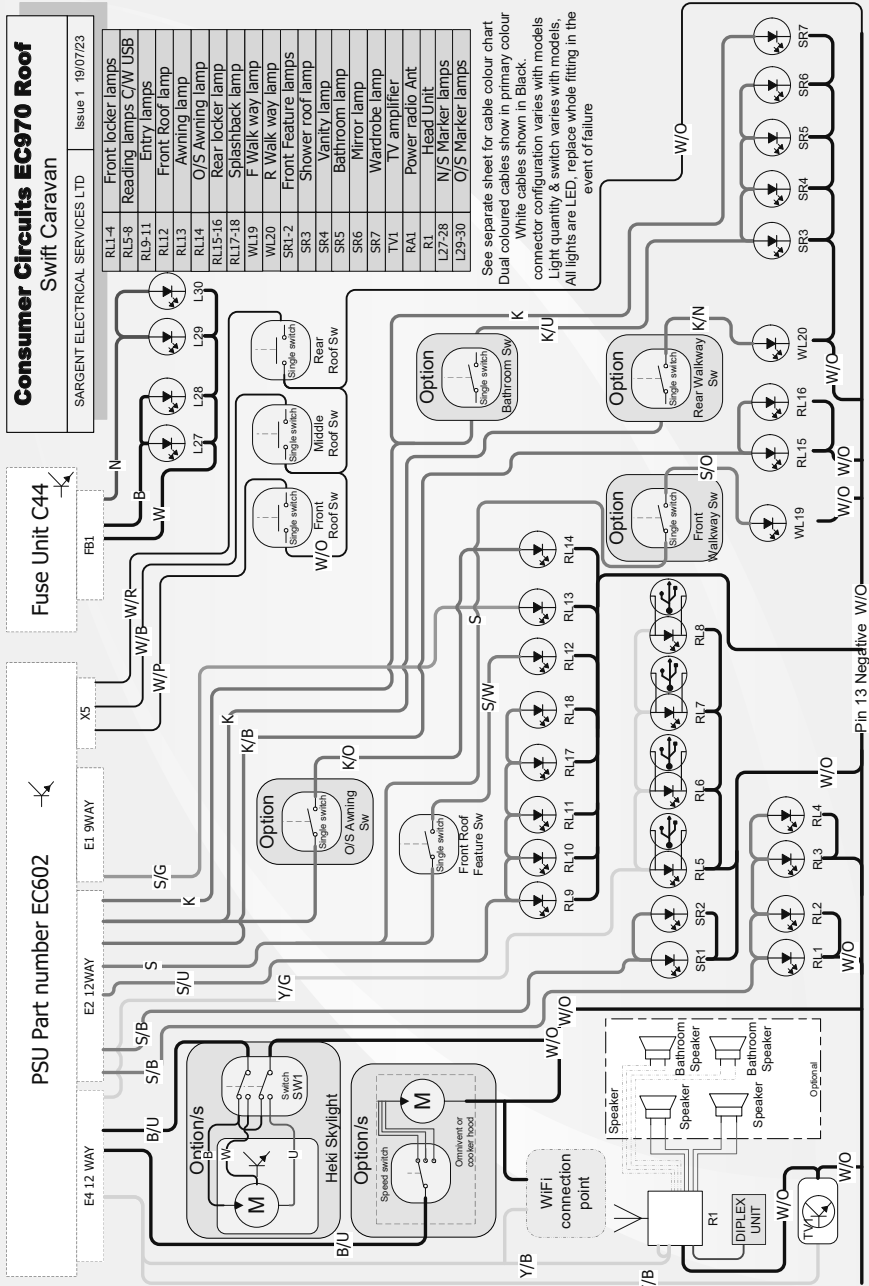

Copyright Sargent Electrical Services Ltd. 2023 all rights reserved. Subject to change without prior notice.

Wiring Diagrams - Power Circuits

Basecamp

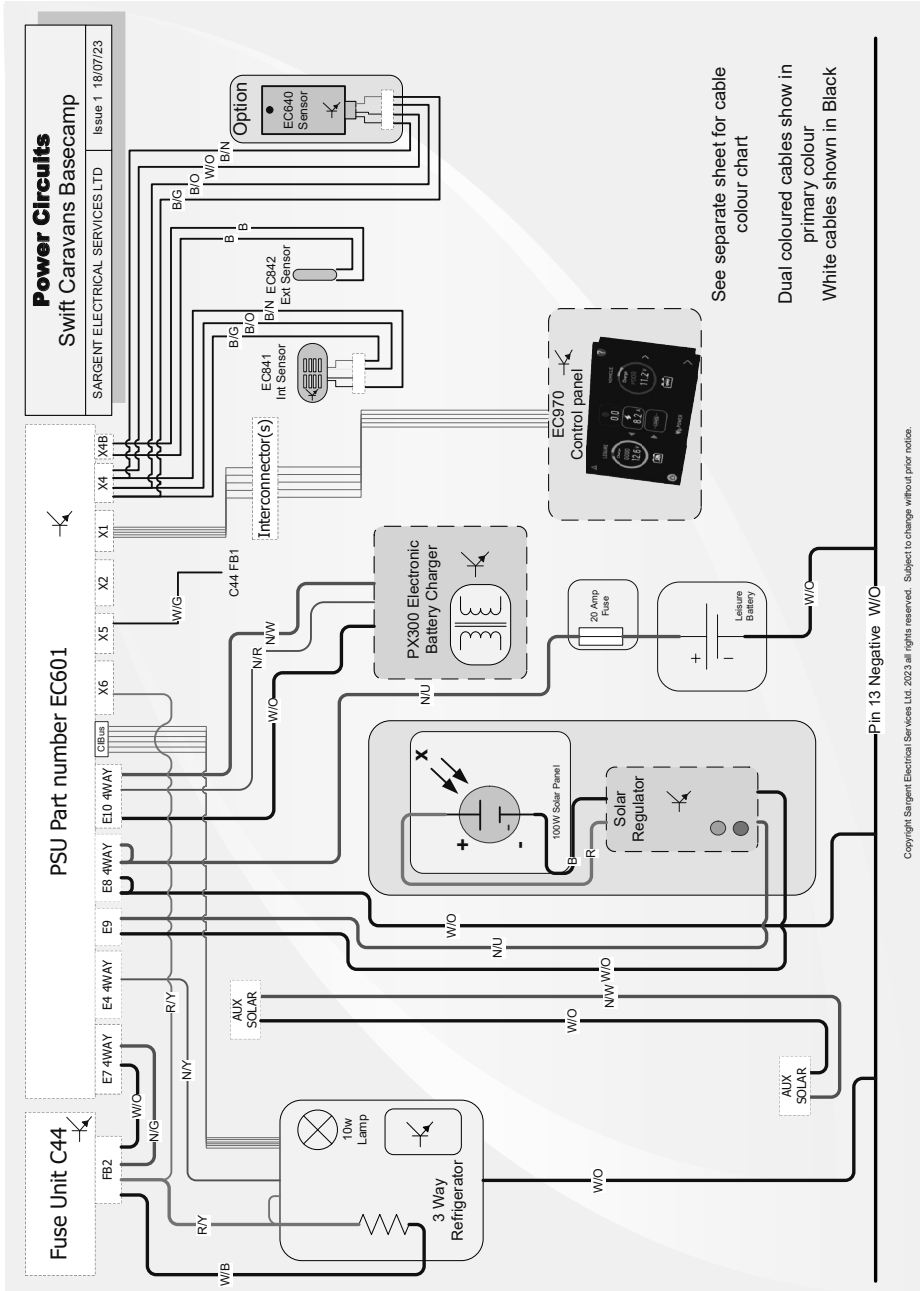

Copyright Sargent Electrical Services Ltd. 2023 all rights reserved. Subject to change without prior notice.

Wiring Diagrams - Power Circuits

Sprite and Sprite Grande

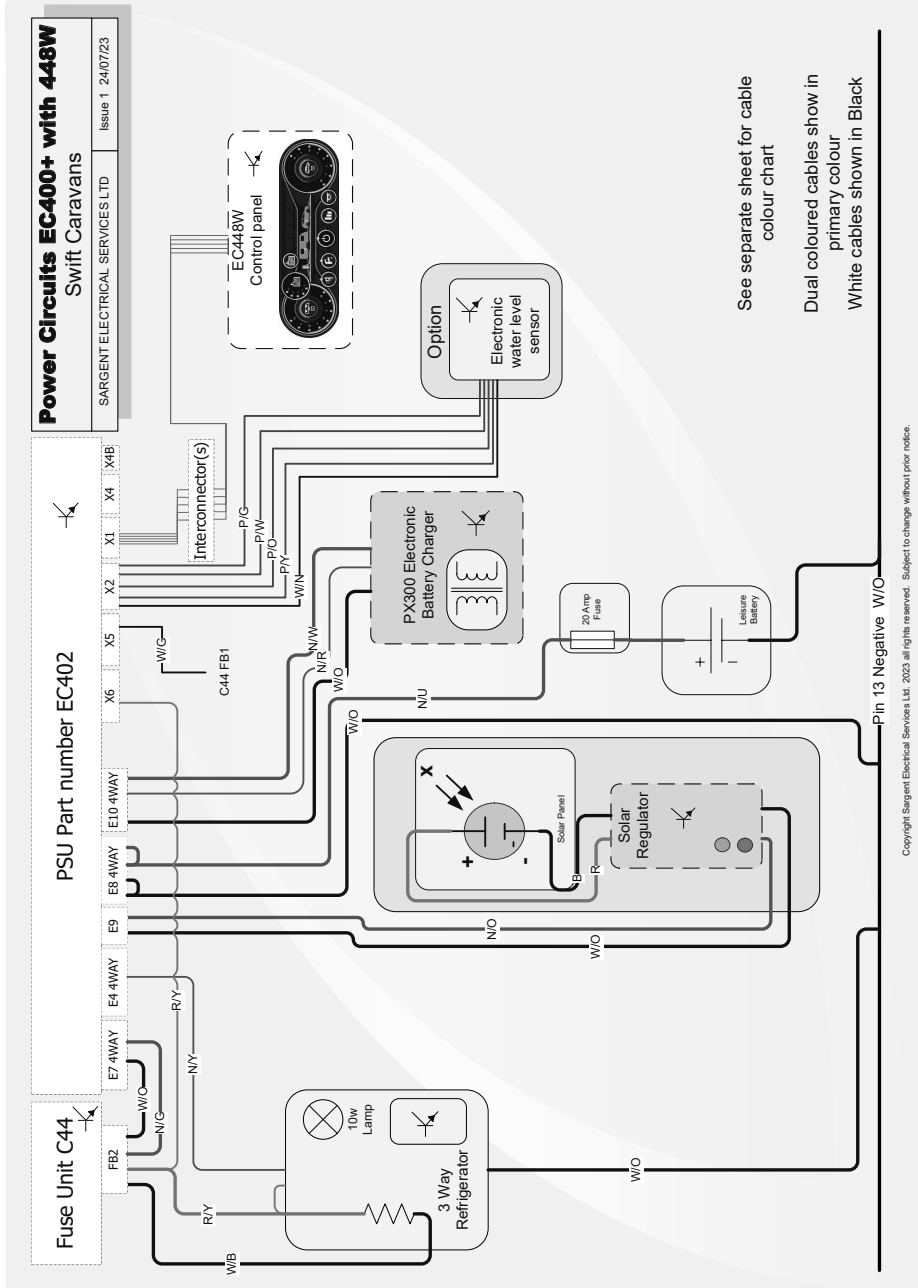

Wiring Diagrams - Power Circuits

Challenger and Challenger Grande

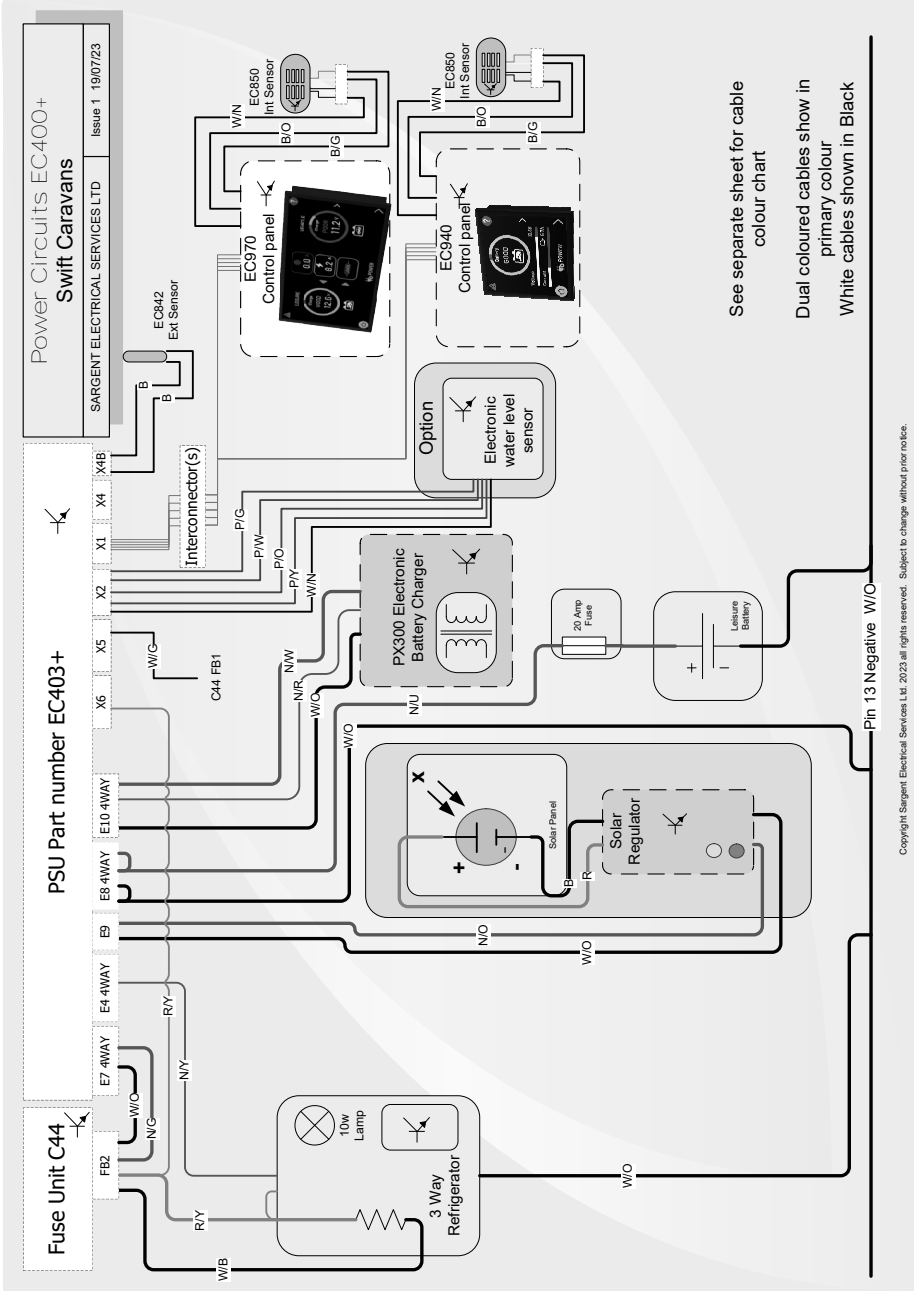

See separate sheet for cable colour chart

Dual coloured cables show in primary colour

White cables shown in Black

Copyright Sargent Electrical Services Ltd. 2023 all rights reserved. Subject to change without prior notice.

Wiring Diagrams - Power Circuits

Elegance Grande

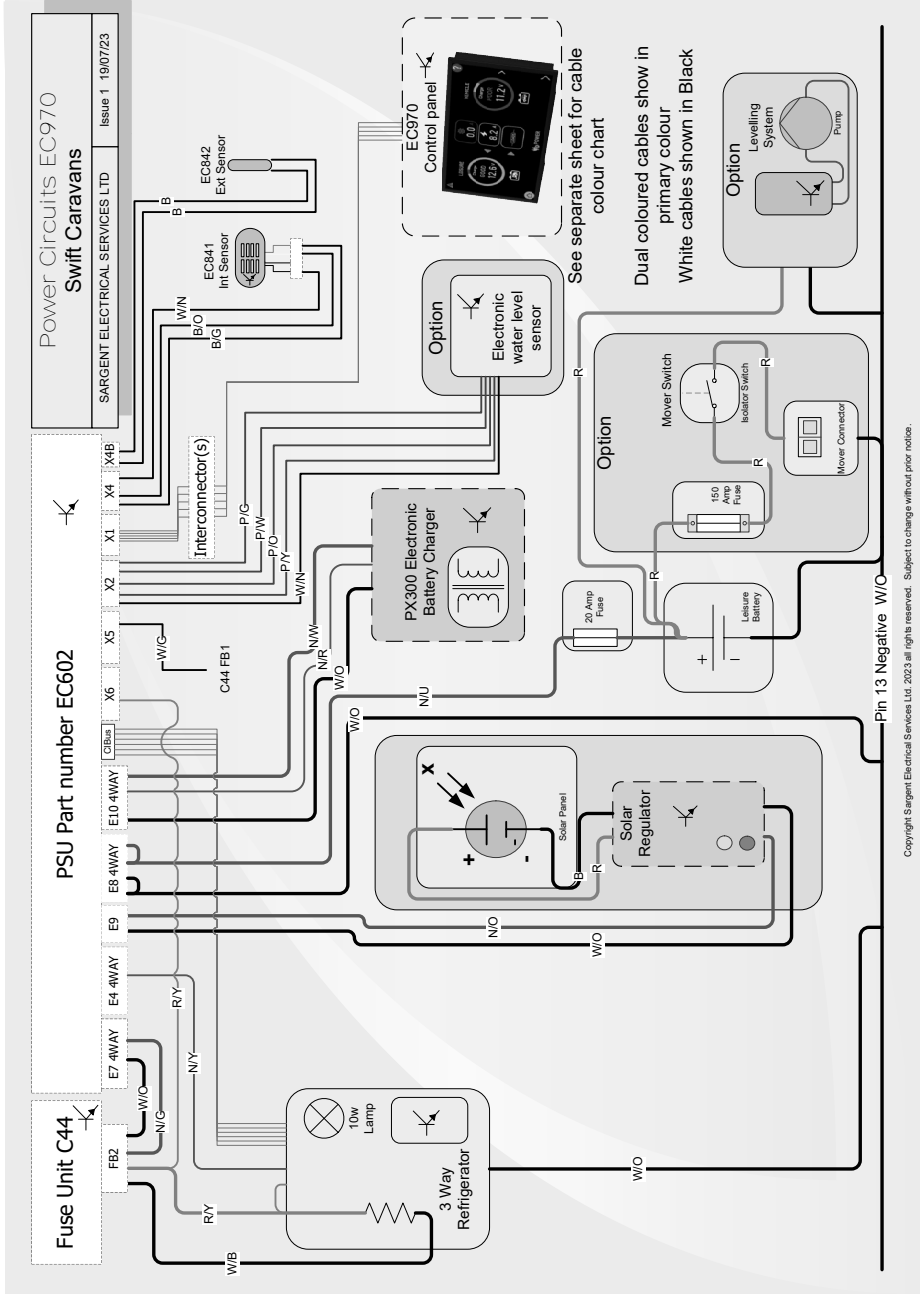

Copyright Sargent Electrical Services Ltd. 2023 all rights reserved. Subject to change without prior notice.

Wiring Diagrams - 230V Circuits

Basecamp

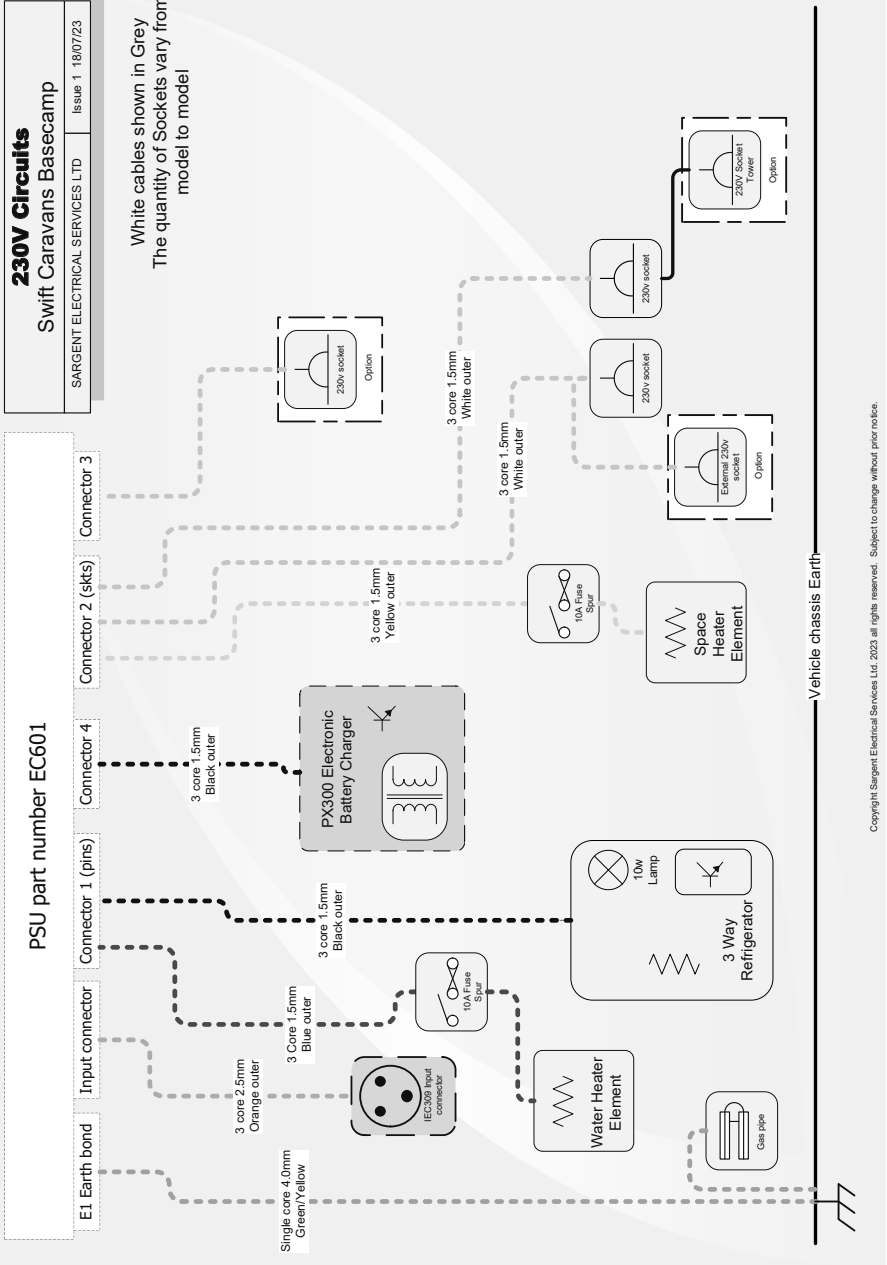

Copyright Sargent Electrical Services Ltd. 2023, all rights reserved. Subject to change without prior notice.

Wiring Diagrams - 13 Pin Socket

ISO 11446 Circuits
Swift Group Caravans (where applicable)
 SARGENT ELECTRICAL SERVICES LTD Issue 01 19/07/23

It is possible to get adaptors that convert two sockets on the towbar to a single 13 pin ISO socket, and vice versa.

Connection lead from 12N 7 pin socket plus 12S 7 pin socket to 13pin Euro Socket. (Converts a vehicle with 2 x 7 pin sockets to a caravan with a 13 pin plug)

Please be aware that some car and adaptor manufacturers don't provide the fridge power connections

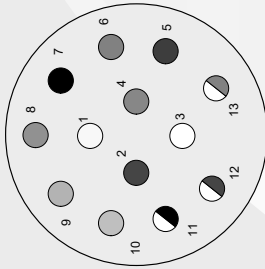

11446 Plug Connector viewed from cable entry on plug



Pin No	Core Colour	Core Size	Function
1	Yellow	1.5	Left Hand Indicator Light
2	Blue	1.5	Rear Fog Warning Light(s)
3	White	2.5	Earth for pins 1 - 8
4	Green	1.5	Right Hand Indicator Light
5	Brown	1.5	Right Hand Tail Light
6	Red	1.5	Brake Lights
7	Black	1.5	Left Hand Tail Light
8	Pink	1.5	Reverse Light(s)
9	Orange	2.5	Car +ve
10	Slate (Grey)	2.5	Fridge +ve
11	White/Black	2.5	Earth for pin 10
12	White/Blue	1.5	Not Yet Allocated
13	White/Red	2.5	Earth for pin 9

Wiring Diagrams - Cable Colour Chart

Example



Y/U

Yellow cable with Blue stripe

Cable Colour Chart

Swift range

SARGENT ELECTRICAL SERVICES LTD Issue 1 19/07/23

12V Cable Colours

B	BLACK
N	BROWN
R	RED
O	ORANGE
Y	YELLOW
G	GREEN
U	BLUE
P	PURPLE
S	SLATE GREY
W	WHITE
K	PINK

230V Cable Colours

B	BLACK
N	BROWN
W	WHITE
O	ORANGE
Y	YELLOW
G	GREEN
U	BLUE

Bulb Replacement

ROAD LIGHT BULB ACCESS

REAR LIGHT CLUSTERS (CONTAINING INDICATOR, TAIL / STOP, REVERSE AND FOG LAMPS):

- These multi-function lights are LED and have no user serviceable parts inside.
- Replacement clusters can be fitted in the following way:
- Remove three screws visible around the perimeter of the cluster
- Pull the cluster away from the rear panel of the tourer, taking care to not put excessive strain on the electrical connections behind the lamp
- Unplug the electrical connection from the rear of the lamp, by releasing the tab and lifting the connector upwards relative to the cluster
- Plug the connector back into the replacement lamp, position the lamp into the recess and replace the three fixing screws.

FRONT LOW LEVEL MARKER / POSITION LAMPS (CLEAR LENSE)

- These lamps are LED and have no user serviceable parts inside.
- Replacements should be undertaken by your dealer, as the lamps are sealed onto the mounting panel.

HIGH LEVEL BRAKE LAMP

- This lamp is single piece and has no user serviceable parts inside.
- Replacements should be undertaken by your dealer, as the lamps are sealed onto the mounting panel.

NUMBER PLATE LAMPS

- These lamps are single piece and have no user serviceable parts inside.
- Replacements should be undertaken by your dealer, as the lamps are sealed onto the mounting panel.

SIDE MARKER / POSITION LAMPS (AMBER LENSE)

- These lamps are LED and have no user serviceable parts inside.
- Replacements should be undertaken by your dealer, as the lamps are sealed onto the mounting panel.

UPPER SIDE MARKER / POSITION LAMPS (RED AND WHITE LENSE)

- These lamps are LED and have no user serviceable parts inside.
- Replacement should be undertaken by your dealer, as the lamp is sealed onto the mounting panel.

Dealer Special specification based on Elegance Grande

Based on Elegance Grande	Elegance 780 Grande	Elegance 835 Grande	Elegance 845 Grande
Dealer			
COUPLANDS	BESSACARR BY DESIGN 780	BESSACARR BY DESIGN 835	BESSACARR BY DESIGN 845
Berths	4	4	4
Axles	1	2	2
Internal Length (bed box height)	5.95m / 19'6"	6.36m / 20'10"	6.36m / 20'10"
Overall Width*	2.45m / 8'0"	2.45m / 8'0"	2.45m / 8'0"
Overall Height (inc. TV Aerial)*	2.61m / 8'7"	2.59m / 8'6"	2.59m / 8'6"
Maximum Internal Headroom	1.95m / 6'5"	1.95m / 6'5"	1.95m / 6'5"
Overall Length*	7.57m / 24'10"	7.98m / 26'2"	7.98m / 26'2"
Awning A / A dimension	10.49m / 34'5"	10.49m / 34'5"	10.49m / 34'5"
Mass in Running Order (inc. tolerance)	1744kg / 34.3cwt Est	1941kg / 38.2cwt Est	1931kg / 38.0cwt Est
Maximum Technical Permissible Laden Mass (Lower limit)	1900kg / 37.4cwt Est	2101kg / 41.4cwt Est	2091kg / 41.2cwt Est
Maximum Technical Permissible Laden Mass (Upper limit)	1900kg / 37.4cwt	2250kg / 44.3cwt	2250kg / 44.3cwt
Total user Payload	156kg / 3.1cwt	160kg / 3.1cwt	160kg / 3.1cwt
Personal Effects	156kg / 3.1cwt	160kg / 3.1cwt	160kg / 3.1cwt
Options	0kg / 0.0cwt	0kg / 0.0cwt	0kg / 0 cwt
Tyre Size	215/60 R17 109	215/45 R17 91	215/45 R17 91
Tyre pressure at Lower limit MTPLM	65 psi / 4.5 bar	46 psi / 3.2 bar	46 psi / 3.2 bar
Tyre pressure at Upper limit MTPLM	65 psi / 4.5 bar	49 psi / 3.4 bar	49 psi / 3.4 bar
Static Load on Coupling Head	100kg	120kg	120kg
Thermal Insulation Grade	THREE	THREE	THREE
Bed Sizes			
Front Double	218cm x 126cm / 7'2" x 4'2"	218cm x 126cm / 7'2" x 4'2"	218cm x 126cm / 7'2" x 4'2"
Rear Double	191cm x 133cm / 6'3" x 4'4"	191cm x 133cm / 6'3" x 4'4"	191cm x 133cm / 6'3" x 4'4"

Masses: The masses are calculated in accordance to EU regulation 1230 / 2012 and NCC code of practice 304.

The Mass in Running Order (MRO) comprises:

1. The mass of the empty caravan as supplied by Swift including loose items such as the hook-up cable, kit bag, entrance step, manuals etc.
2. 10kg allowance for LPG

The MRO is calculated with the fresh water tank, toilet flush tank and water heater empty. If you travel with water in the fresh water tank, toilet flush tank and the water heater the payload will reduce accordingly.

The personal effects is based on the number of berths and the length of the caravan and includes an allowance of 20kg for a leisure battery.

The Maximum Technical Laden Mass (MTPLM) is the maximum mass allowed when the caravan is fully laden.

WARNING: Under no circumstances should the MTPLM be exceeded

Bed Sizes: Please note that the front double bed sizes quoted are for seating configurations without chest of drawers. The front double bed width for a layout with a chest of drawers fitted will be reduced by 0.4m (1'4") from that stated.

Awning sizes: Due to the varying awning designs and sizes the awning sizes given are approximate only. Specific awning sizes must be confirmed by your dealer or the awning manufacturer prior to purchase.

Est = Estimated weight or bed size

**The dimensions given are approximate due to slight variations in suspension ride heights, loading conditions and tyre pressures.

Customers should verify the actual dimensions of their touring caravan before committing to anything that could be impacted by these dimensions

Please note: Any dealer fit options will reduce the overall payload available to the user of the caravan.

If you require additional payload it is possible to upgrade the MTPLM to the upper limit. Please contact your caravan dealer for more information.

Elegance 850 Grande	Elegance 860 Grande
BESSACARR BY DESIGN 850	BESSACARR BY DESIGN 860
4	4
2	2
6.36m / 20'10"	6.36m / 20'10"
2.45m / 8'0"	2.45m / 8'0"
2.59m / 8'6"	2.59m / 8'6"
1.95m / 6'5"	1.95m / 6'5"
7.98m / 26'2"	7.98m / 26'2"
10.49m / 34'5"	10.49m / 34'5"
1931kg / 38.0cwt Est	1885kg / 37.1cwt Est
2091kg / 41.2cwt Est	2045kg / 40.3cwt Est
2250kg / 44.3cwt	2250kg / 44.3cwt
160kg / 3.1cwt	160 kg / 3.1cwt
160kg / 3.1cwt	160kg / 3.1cwt
0kg / 0 cwt	0kg / 0 cwt
215/45 R17 91	215/45 R17 91
46 psi / 3.2 bar	45 psi / 3.1 bar
49 psi / 3.4 bar	49 psi / 3.4 bar
120kg	120kg
THREE	THREE
194cm x 122cm / 6'4" x 4'0"	194cm x 122cm / 6'4" x 4'0"
191cm x 143cm / 6'3" x 4'8"	191cm x 143cm / 6'3" x 4'8"

Bed make up

Bed make up in Basecamp front end

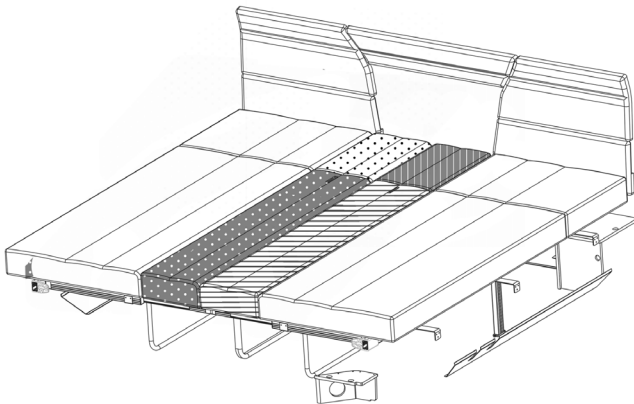
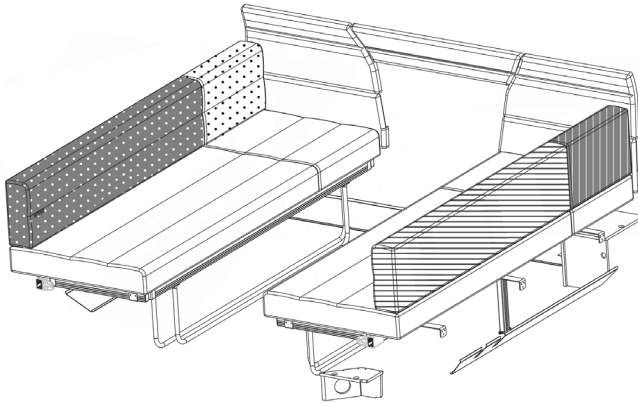

Bed make up

Bunk bed make up in Basecamp 4

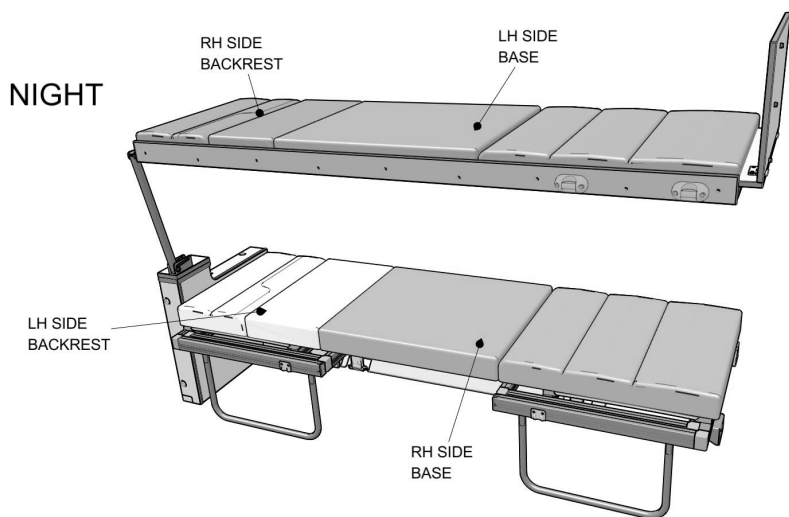
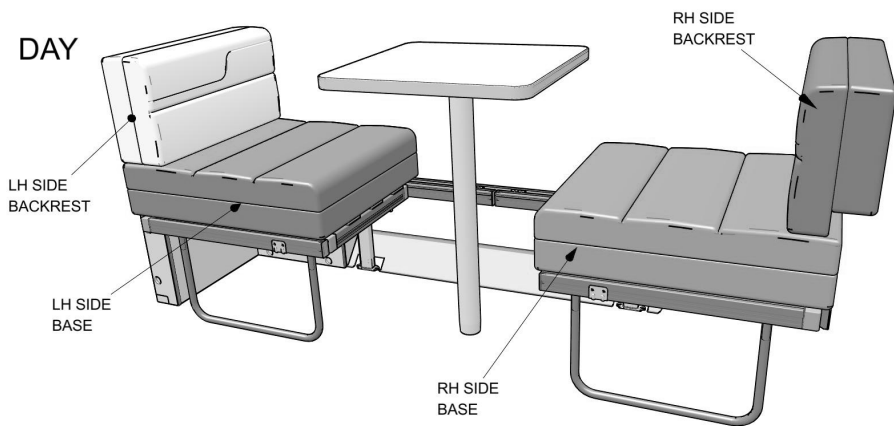

Bed make up

Bed make up in Sprite Quattro MB

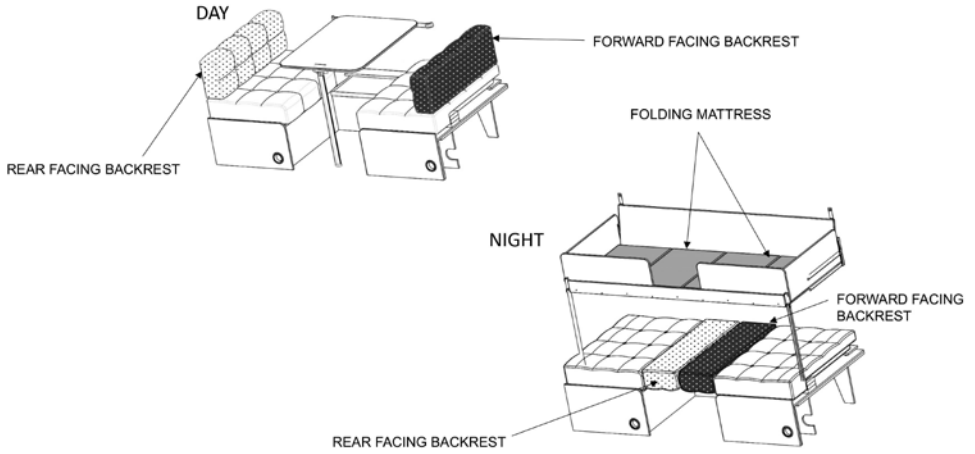

Bed make up on Sprite Major 6 TD

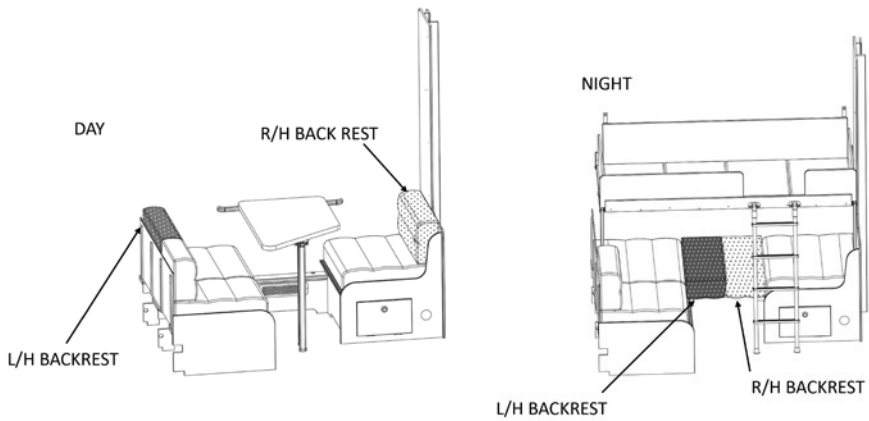

Bed make up

Bed make up in Sprite Grande, Challenger Grande and Elegance Grande

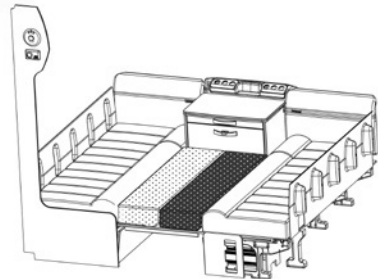
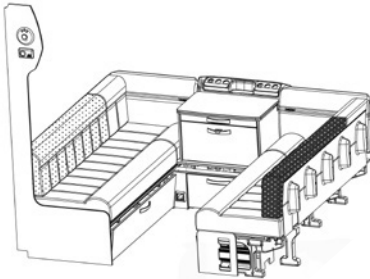
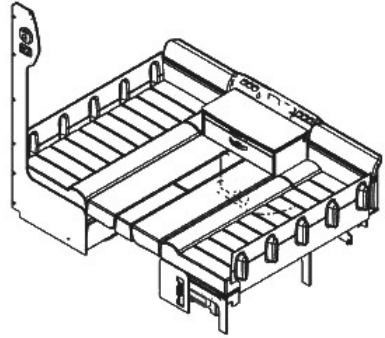
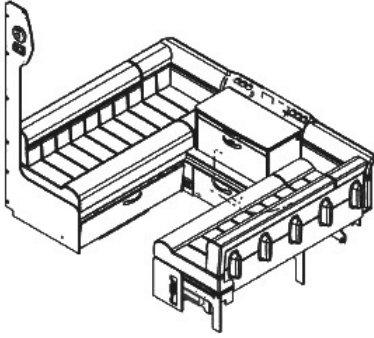

Bed make up

Front "L" Bed make up in Elegance Grande

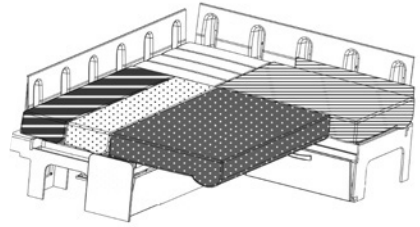
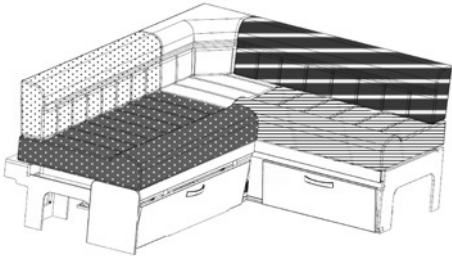

Bed make up in Sprite Grande mid bed

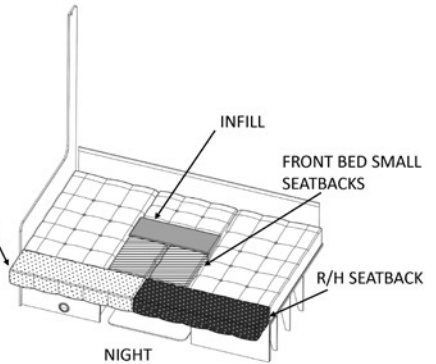
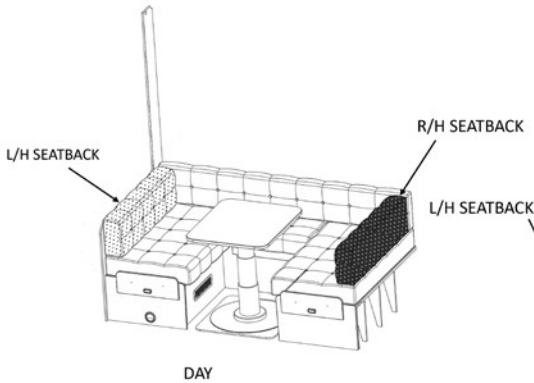







SWIFT

SWIFT GROUP

Dunswell Road

Cottingham

East Yorkshire

HU16 4JX

Tel: 01482 875740

Fax: 01482 840082

Customer Experience Team

enquiries@swiftleisure.co.uk

FIND OUT MORE AT **SWIFTGROUP.CO.UK**